

Collection of Datasheets

**Compressors for R134a  
12 - 24V Direct Current**

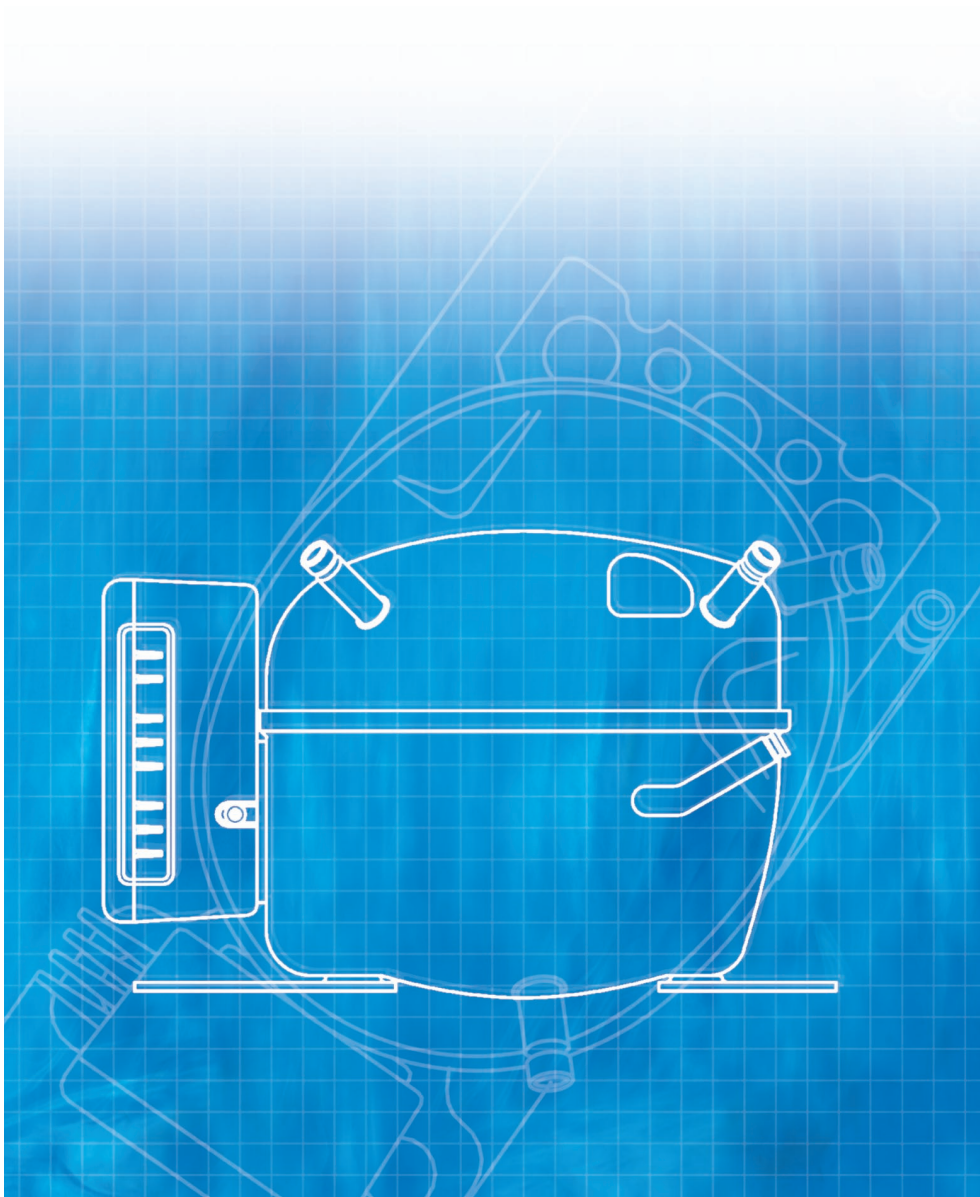

<b>Contents</b>	General	Page 2
	Electric circuit	3
	Wiring diagram	3
	Voltage range	3
	Cable dimensions	3
	Thermostat connection	4
	Compressor speed	4
	Fan connection	4
	Troubleshooting	4
	LED connection	4
	Protection systems	5
	Technical data BD35F	6
	Performance data BD35F	7
	Technical data BD50F	8
	Performance data BD50F	9
	Data stamping	10
	Mounting the electronic unit	10
	Connectors	10
	Mounting accessories	10
	Filter drier selection	10
	Sectional view	11

## General

Danfoss variable speed refrigeration compressors type BD35F and BD50F are designed for connection to 12V and 24V DC power supply and for refrigerant R134a ( $\text{CF}_3\text{-CH}_2\text{F}$ ).

The compressors are intended especially for use in mobile applications, e.g. pleasure-craft, commercial shipping, caravans, lorries, buses, etc. But due to their low energy consumption and the option for a wide supply voltage range, the compressors are also very suitable for stationary applications powered by photovoltaic solar panels.

The compressors can be used in refrigerators and freezers and are designed for capillary tube as the throttling device.

The compressor concept includes an electronic unit which features overload protection and protection against destructive battery discharge. The electronic unit has internal voltage recording and calibration to the applied voltage. The electronic unit may also be powered directly from certain types of electronic power supply units and thus no battery is required.

In addition to being especially quiet in operation, the compressors have a low energy consumption. They will operate under continual heeling of 30° such as occurs on yachts.

The BD compressors must be mounted in a dry and clean place. The compressors will withstand storage temperatures down to -35°C.

Condensing temperatures:

Max. 60°C at stable conditions and max. 70°C at peak load.

Ambient temperatures: Min. -10°C; max. 55°C

## Electric circuit

The BD compressors are fitted with a brushless direct current motor which is electronically commutated by an electronic unit.

The electronic unit is delivered separately and must be mounted on the compressor, please see instructions page 10. The electronic unit must always be connected directly to the battery poles or power supply unit terminals. For the protection of the installation an external fuse must be installed in the power supply cable close to the battery or power supply unit. Establish a special wiring for the BD power supply using direct one-piece cables and avoid to use the existing wiring.

If the chassis is used as a conductor, a proper connection between cable and chassis must be established.

Wrong polarity applied to the electronic unit does not destroy the unit, however, the compressor does not work.

If the compressor is planned to be stopped for a longer period, a main switch can be installed. The switch must have a contact system rated min. 20A, otherwise the voltage drop over the contacts will cause the battery protection to cut off the compressor earlier than intended.

## Wiring diagram

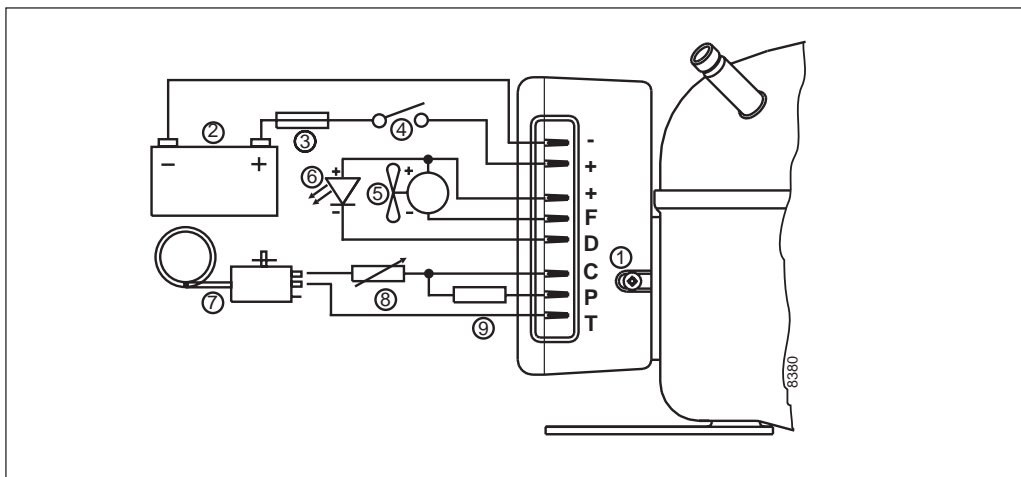

- 1: Electronic unit
- 2: Battery
- 3: Fuse
- 4: Main switch (optional)
- 5: Fan (optional)
- 6: LED - Light Emitting Diode (optional)
- 7: Thermostat
- 8: Resistor for presetting speed (optional)
- 9: Resistor for presetting battery protection voltage (optional)

## Voltage range

12V systems: From 10.4V (9.6V) to 17V.

24V systems: From 22.8V (21.3V) to 31.5V.

The low voltage limits stated in brackets ( ) can be established if a connection is made between the terminals C and P, please see also the passage **Optional battery protection settings** page 5.

The electronic unit will calibrate to the applied voltage. This means that if the battery voltage is less than 17V, the electronic unit assumes that it is working in a 12V system. If the voltage is higher than 17V, the electronic unit assumes that it is working in a 24V system. Consequently, the compressor does not run at power supply voltages between about 17V and the desired battery protection cut-out voltage for 24V systems.

A continuous voltage range from 9.6V to 31.5V can be established if a 220kΩ resistor (wiring diagram item 9) is connected between the terminals C and P. This wide voltage range makes the BD compressors very suitable for photovoltaic powering.

## Cable dimensions

To ensure correct start and operating conditions, the following cable dimensions must be observed:

Cable cross-section mm <sup>2</sup>	Max length* m	
	12V operation	24V operation
2.5	2.5	5
4	4	8
6	6	12
10	10	20

\* "Length" means the distance between battery and electronic unit.

### Thermostat connection

BD compressors can operate with normal mechanical type thermostats as used in refrigeration appliances, or with electronic thermostats. Always use new thermostats. The thermostat is connected between the terminals C and T of the electronic unit. The compressor current does not flow through the thermostat contacts. When the thermostat is cut out there will still be power on to the electronic unit. A system with no stand-by power consumption can be established if the thermostat (7) is replaced by a jumper between the terminals C and T, and the main switch (4) is replaced by a thermostat. In this case the full current to the compressor flows through the thermostat, which must be rated accordingly.

### Compressor speed

R (8) Ω	Motor speed rpm	Contr. circ. Current mA
0	2,000	5
277	2,500	4
692	3,000	3
1523	3,500	2

Without any resistor in the control circuit, the compressor will run with a fixed speed of **2,000 rpm** when the thermostat is switched on.

Other fixed speeds in the range between **2,000** and **3,500 rpm** can be obtained when a resistor (8) is installed to adjust the current (mA) of the control circuit, please see wiring diagram page 3.

### Fan connection

If a fan is to be used, it must be connected to the electronic unit terminals + and F. Always use a 12V fan, also in 24V systems, as the electronic unit will automatically reduce the applied voltage to 12V for the fan. The max. load on the electronic unit is  $0.5A_{\text{average}}$  or  $1A_{\text{peak}}$ . The fan is allowed to start with a higher current for the first 2 seconds. If the fan becomes overloaded, both fan and compressor will be cut out by the overload protection.

### Troubleshooting

To diagnose why a compressor comes to an unintended stop, it is recommended to have a Light Emitting Diode (LED) installed between the terminals + and D, please see page 3 and 4. Provided that the electronic unit is properly connected to the power supply, and the thermostat is on, the number of flashes emitted by the LED will give a hint about the reason for the interruption of the compressor operation.

The motor windings can be checked for defects by measuring the resistance between the current lead-in pins. If the measured values between all 3 pins are approximately the same, the motor is most likely all right.

The electronic unit is not to be repaired, it should not be opened at all.

### LED connection

A 10mA Light Emitting Diode (LED) for compressor operation monitoring can be connected between the terminals + and D.

Number of flashes	Error type
5	<b>Thermal cut-out of electronic unit</b> (If the refrigeration system has been too heavily loaded, or if the ambient temperature is high, the electronic unit will run too hot).
4	<b>Minimum motor speed error</b> (If the refrigeration system is too heavily loaded, the motor cannot maintain minimum speed at approximately 1,850 rpm).
3	<b>Motor start error</b> (The rotor is blocked or the differential pressure in the refrigeration system is too high (>5 bar)).
2	<b>Fan over-current cut-out</b> (The fan loads the electronic unit with more than $1A_{\text{peak}}$ ).
1	<b>Battery protection cut-out</b> (The voltage is outside the cut-out setting).

Operational errors will cause the LED to flash a number of times. The number of flashes depends on what kind of operational error was recorded.

Each flash will last  $\frac{1}{4}$  second.

After the actual number of flashes there will be a delay with no flashes, so that the sequence for each error recording is repeated every 4 seconds.

### Protection systems

The BD compressor protection system facilitates protection against compressor overload and start failure, fan overload and electronic unit overheating as well as destructive battery discharge. When an overload protection is activated, the compressor enters a cycle in which it makes start attempts at about 60 seconds intervals until a successful start is achieved.

### Overload protections

The compressor overload and start protection cuts off power to the compressor if the compressor speed drops below approximately 1,850 rpm or this motor speed is not reached during the start sequence. Possible reasons for overload protection activating could be excess refrigeration system pressures during operation or lack of pressure equalizing at start.

The fan overload protection stops the compressor and fan if the fan current exceeds  $0.5A_{\text{average}}$  or  $1A_{\text{peak}}$ .

An overheating of the electronic unit heat sink will cause the compressor to stop. Restart will occur automatically when a normal temperature has been reached.

If a fan is installed, it will continue to run if the compressor stops due to overload or electronic unit overheating.

### Voltage protection

If a voltage outside the specified range is applied to the electronic unit, the compressor does not start, or it stops if the voltage limit is exceeded during operation. The compressor will restart automatically about 1 minute after the supply voltage has reached the reset voltage within the range in question. If a fan is installed, it will start to operate without a delay as soon as the reset voltage is reached.

### Battery protection

To ensure sufficient battery power for proper compressor operation or to avoid permanent damage to the battery because of heavy discharge, the BD electronic unit facilitates also a battery protection. The compressor is stopped and restarted again according to the decided voltage limits measured on the + and - terminals of the electronic unit.

#### Standard battery protection settings

12V cut-out V	12V cut-in V	24V cut-out V	24V cut-in V
10.4	11.7	22.8	24.2

Other battery protection settings are optional if a connection, which includes a resistor, is established between terminals C and P, please see the wiring diagram page 3.

#### Optional battery protection settings

Resistor (R9) kΩ	12V cut-out V	12V cut-in V	12V max. voltage	24V cut-out V	24V cut-in V	24V max. voltage
0	9.6	10.9	17.0	21.3	22.7	31.5
1.6	9.7	11.0	17.0	21.5	22.9	31.5
2.4	9.9	11.1	17.0	21.8	23.2	31.5
3.6	10.0	11.3	17.0	22.0	23.4	31.5
4.7	10.1	11.4	17.0	22.3	23.7	31.5
6.2	10.2	11.5	17.0	22.5	23.9	31.5
8.2	10.4	11.7	17.0	22.8	24.2	31.5
11	10.5	11.8	17.0	23.0	24.5	31.5
14	10.6	11.9	17.0	23.3	24.7	31.5
18	10.8	12.0	17.0	23.6	25.0	31.5
24	10.9	12.2	17.0	23.8	25.2	31.5
33	11.0	12.3	17.0	24.1	25.5	31.5
47	11.1	12.4	17.0	24.3	25.7	31.5
82	11.3	12.5	17.0	24.6	26.0	31.5
220	9.6	10.9				31.5

## Technical data BD35F

### General

Compressor	<b>BD35F</b>
Code number: Comp. without electronic unit	101Z0200
Code number: Electronic unit 12-24V DC, single packing	101N0210
Code number: Electronic unit 12-24V DC, industrial packing, 30 pcs.	101N0211

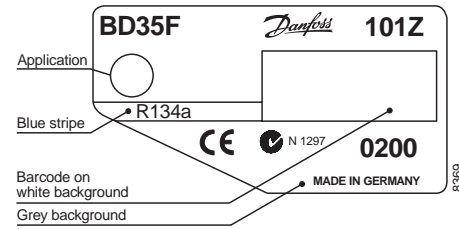

### Application

Application		LBP/MBP/(HBP)
Evaporating temperature range	°C	-30 to 0 (10)
Voltage		12 - 24V DC
Max. voltage		31.5V
Max. machine compartment temperature	°C	55
Comp. cooling at ambient temp.	43°C	S or F <sub>1</sub> *

\* depending on application



- S = Static cooling normally sufficient
- O = Oil cooling
- F<sub>1</sub> = Fan cooling 1.5 m/s  
(compressor compartment temperature equal to ambient temperature)
- F<sub>2</sub> = Fan cooling 3.0 m/s necessary

### Design

Displacement	cm <sup>3</sup>	2.00
Oil quantity	cm <sup>3</sup>	150
Maximum refrigerant charge	g	300
Free gas vol. in compressor housing	cm <sup>3</sup>	870
Weight: Compressor/Electronic unit	kg	4.3/0.25

### Motor

Motor type		Variable Speed
Resistance, all 3 windings (25°C)	Ω	2.3
Approvals		E4 72/245 95/54 0277 00

### Dimensions

Height	mm	A	137
		B	135
		B1	128
		B2	73
Suction connector	location/I.D. mm	C	6.2±0.09
Process connector	location/I.D. mm	D	6.2±0.09
Discharge connector	location/I.D. mm	E	5.0 +0.12/+0.20
Compressors on a pallet	pcs.		120

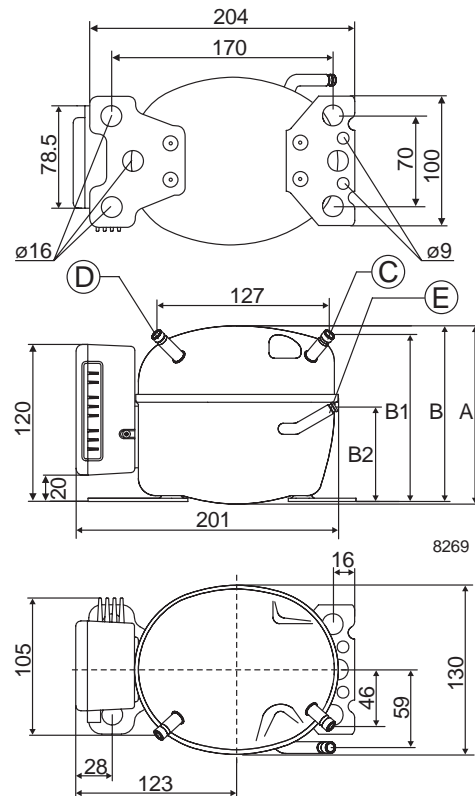

**Performance data  
BD35F**
**Capacity (EN 12900/CECOMAF)**
**watt**

rpm \ °C	-30	-25	-23.3	-20	-15	-10	-5	0	5	10
2,000	15.8	23.9	26.9	33.1	43.8	56.6	71.7	89.9	111	136
2,500	20.2	29.9	33.5	41.2	54.6	70.7	89.7	112	139	
3,000	22.5	32.4	36.5	45.4	61.8	81.7	105	133		
3,500	26.2	35.9	40.4	50.5	69.8	93.6	122			

**Capacity (ASHRAE)**
**watt**

rpm \ °C	-30	-25	-23.3	-20	-15	-10	-5	0	5	10
2,000	19.5	29.4	33.1	40.7	54.0	69.8	88.6	111	137	169
2,500	24.9	36.8	41.3	50.7	67.3	87.1	111	139	172	
3,000	27.7	39.9	44.9	55.9	76.1	101	130	164		
3,500	32.2	44.2	49.7	62.2	86.0	115	150			

**Power consumption**
**watt**

rpm \ °C	-30	-25	-23.3	-20	-15	-10	-5	0	5	10
2,000	17.6	23.4	25.3	28.7	33.6	38.3	43.0	48.0	53.4	59.5
2,500	23.3	30.9	33.3	37.8	44.1	50.2	56.2	62.3	68.7	
3,000	29.9	36.0	38.3	43.0	50.7	58.7	66.8	74.8		
3,500	36.0	42.8	45.4	50.8	59.5	68.9	78.5			

**Current consumption (for 24V applications the figures must be halved)**
**A**

rpm \ °C	-30	-25	-23.3	-20	-15	-10	-5	0	5	10
2,000	1.5	2.0	2.1	2.4	2.8	3.2	3.6	4.0	4.5	5.0
2,500	1.9	2.6	2.8	3.2	3.7	4.2	4.7	5.2	5.8	
3,000	2.5	3.0	3.2	3.6	4.2	4.9	5.6	6.2		
3,500	3.0	3.6	3.8	4.3	5.0	5.7	6.5			

**COP (EN 12900/CECOMAF)**
**W/W**

rpm \ °C	-30	-25	-23.3	-20	-15	-10	-5	0	5	10
2,000	0.90	1.02	1.06	1.15	1.31	1.48	1.67	1.87	2.08	2.29
2,500	0.87	0.97	1.01	1.09	1.24	1.41	1.60	1.80	2.02	
3,000	0.75	0.90	0.95	1.06	1.22	1.39	1.58	1.78		
3,500	0.73	0.84	0.89	1.00	1.17	1.36	1.55			

**COP (ASHRAE)**
**W/W**

rpm \ °C	-30	-25	-23.3	-20	-15	-10	-5	0	5	10
2,000	1.10	1.25	1.31	1.42	1.61	1.82	2.06	2.31	2.57	2.84
2,500	1.07	1.19	1.24	1.34	1.53	1.74	1.97	2.23	2.50	
3,000	0.93	1.11	1.17	1.30	1.50	1.72	1.95	2.20		
3,500	0.89	1.03	1.09	1.23	1.44	1.68	1.91			

Test conditions	EN 12900/CECOMAF	ASHRAE
Condensing temperature	55°C	55°C
Ambient and suction gas temp.	32°C	32°C
Liquid temperature	55°C	32°C
Static cooling, 12V DC		
1 Watt = 0.86 kcal/h		

## Technical data BD50F

### General

Compressor	<b>BD50F</b>
Code number: Comp. without electronic unit	101Z1220
Code number: Electronic unit 12-24V DC, single packing	101N0210
Code number: Electronic unit 12-24V DC, industrial packing, 30 pcs.	101N0211

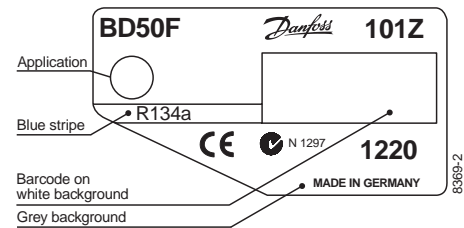

### Application

Application		LBP/MBP/(HBP)
Evaporating temperature range	°C	-30 to 0 (10)
Voltage		12 - 24V DC
Max. voltage		31.5V
Max. machine compartment temperature	°C	55
Comp. cooling at ambient temp.	43°C	S or F <sub>1</sub> *

\* depending on application

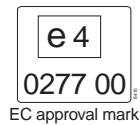

- S = Static cooling normally sufficient
- O = Oil cooling
- F<sub>1</sub> = Fan cooling 1.5 m/s  
(compressor compartment temperature equal to ambient temperature)
- F<sub>2</sub> = Fan cooling 3.0 m/s necessary

### Design

Displacement	cm <sup>3</sup>	2.50
Oil quantity	cm <sup>3</sup>	150
Maximum refrigerant charge	g	300
Free gas vol. in compressor housing	cm <sup>3</sup>	870
Weight: Compressor/Electronic unit	kg	4.3/0.25

### Motor

Motor type		Variable Speed
Resistance, all 3 windings (25°C)	Ω	2.0
Approvals		E4 72/245 95/54 0277 00

### Dimensions

Height	mm	A	137
		B	135
		B1	128
		B2	73
Suction connector	location/I.D. mm	C	6.2±0.09
Process connector	location/I.D. mm	D	6.2±0.09
Discharge connector	location/I.D. mm	E	5.0 +0.12/+0.20
Compressors on a pallet	pcs.		120

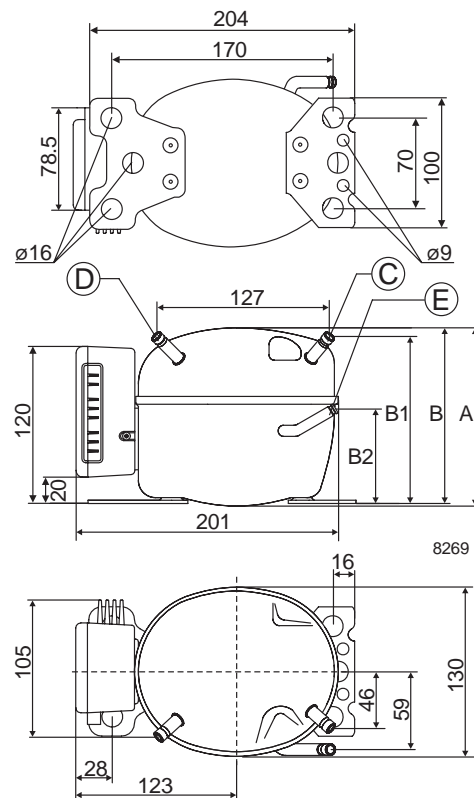



**Performance data  
BD50F**
**Capacity (EN 12900/CECOMAF)**
**watt**

rpm \ °C	-30	-25	-23.3	-20	-15	-10	-5	0	5	10
2,000	20.1	31.0	34.9	42.8	56.3	72.2	91.6	115	144*	178*
2,500	27.0	39.0	43.4	52.7	68.9	88.9	113	144*	181*	
3,000	31.0	45.4	50.6	61.5	80.7	104	134*	171*		
3,500	38.1	53.2	59.1	71.9	95.0	124*	159*			

**Capacity (ASHRAE)**
**watt**

rpm \ °C	-30	-25	-23.3	-20	-15	-10	-5	0	5	10
2,000	24.7	38.3	43.1	52.9	69.5	89.3	113	143	178*	221*
2,500	33.3	48.1	53.6	65.0	85.1	110	140	178*	224*	
3,000	38.2	56.0	62.5	75.9	100	129	166*	212*		
3,500	47.0	65.7	72.9	88.7	117	153*	196*			

**Power consumption**
**watt**

rpm \ °C	-30	-25	-23.3	-20	-15	-10	-5	0	5	10
2,000	25.1	31.8	34.0	38.2	44.7	51.3	58.3	65.8	74.2*	83.5*
2,500	34.1	40.5	42.9	47.8	55.8	64.7	74.3	84.8*	96.1*	
3,000	39.9	49.2	52.2	57.8	66.5	76.4	88.4*	104*		
3,500	50.2	59.3	62.5	69.0	80.2	93.4*	109*			

**Current consumption (for 24V applications the figures must be halved)**
**A**

rpm \ °C	-30	-25	-23.3	-20	-15	-10	-5	0	5	10
2,000	2.2	2.6	2.8	3.1	3.8	4.4	5.1	5.8	6.4*	6.9*
2,500	2.9	3.4	3.6	4.0	4.7	5.4	6.2	7.0*	7.8*	
3,000	3.5	4.2	4.4	4.9	5.6	6.5	7.4*	8.5*		
3,500	4.2	4.9	5.2	5.8	6.7	7.8*	9.0*			

**COP (EN 12900/CECOMAF)**
**W/W**

rpm \ °C	-30	-25	-23.3	-20	-15	-10	-5	0	5	10
2,000	0.80	0.98	1.03	1.12	1.26	1.41	1.57	1.75	1.94*	2.13*
2,500	0.79	0.96	1.01	1.10	1.24	1.37	1.53	1.70*	1.88*	
3,000	0.78	0.92	0.97	1.06	1.21	1.37	1.51*	1.65*		
3,500	0.76	0.90	0.95	1.04	1.19	1.32*	1.45*			

**COP (ASHRAE)**
**W/W**

rpm \ °C	-30	-25	-23.3	-20	-15	-10	-5	0	5	10
2,000	0.99	1.21	1.27	1.38	1.56	1.74	1.94	2.16	2.40*	2.65*
2,500	0.98	1.19	1.25	1.36	1.53	1.70	1.89	2.10*	2.33*	
3,000	0.96	1.14	1.20	1.31	1.50	1.69	1.87*	2.04*		
3,500	0.94	1.11	1.17	1.28	1.46	1.64*	1.80*			

\* Fan cooling of electronic unit compulsory

Test conditions	EN 12900/CECOMAF	ASHRAE
Condensing temperature	55°C	55°C
Ambient and suction gas temp.	32°C	32°C
Liquid temperature	55°C	32°C
Static cooling, 12V DC		
1 Watt = 0.86 kcal/h		

### Data stamping

The data stamping is placed on the top of the compressor, e.g.  
D35F-0200  
F017C127

The first line gives model designation and code no.

D35F = Last part of the model designation (BD35F)  
0200 = Last part of compressor code no. (101Z0200).

The second line gives date of manufacture and motor supplier.

F = manufacturing place (F = Flensburg, Germany)  
01 = Week 1  
7 = 1997  
C = Wednesday (A = Monday etc.)  
12 = Rated DC voltage  
7 = Motor supplier

For the electronic unit, the code for date of manufacture is located on the printed circuit board, visible through the opening on the backside of the housing, where the cables get out.

### Mounting the electronic unit

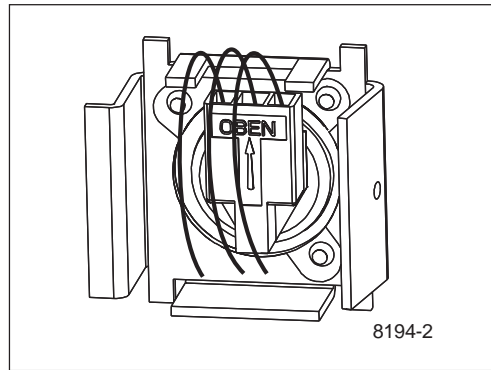

The cable plug of the electronic unit is mounted on the pins of the current lead-in on the compressor. Then the electronic unit itself is mounted on the bracket of the compressor. At first the left side is mounted, then the right side is pressed over the screw on the bracket. The electronic unit snaps on to the bracket and is now securely mounted on the compressor.

In case the electronic unit must be removed from the compressor, the screw has to be loosened.

### Connectors

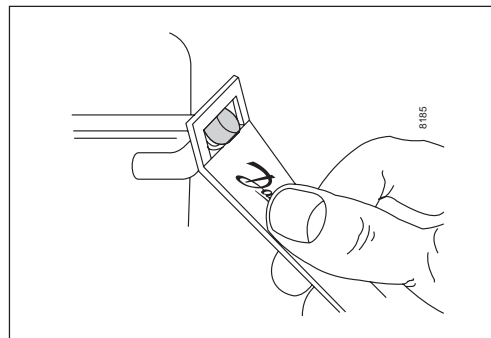

The compressor is equipped with DANCON connectors which consist of a thick-walled, copper-plated steel tube with high corrosion resistance, and a solderability equal to that of conventional copper connectors.

DANCON connectors are equipped with an aluminium cap (Capsolut) which gives a tight sealing.

The seal cap is easily removed with an ordinary pair of pliers or with a special tool.

### Mounting accessories

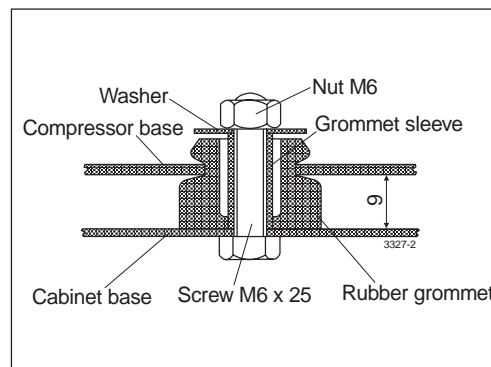

Mounting accessories for BD compressors are supplied as a screw and nut assembly 118-1917. Each assembly 118-1917 is supplied in a bag containing four screws, nuts, washers, grommet sleeves and rubber grommets for mounting one compressor. The screw and nut assembly can be obtained in quantities under code no 118-1918.

### Filter drier selection

Only filter driers which are declared by the manufacturer to be suitable for mobile applications must be used in refrigeration systems with BD35F and BD50F compressors. Filter material powder ending up in the compressor will lead to excessive wear of the piston and transmission parts, and metal particles deposited in the motor windings will cause the compressor to stop because the electric signal back to the electronic unit is disturbed.

**Compressor sectional view**

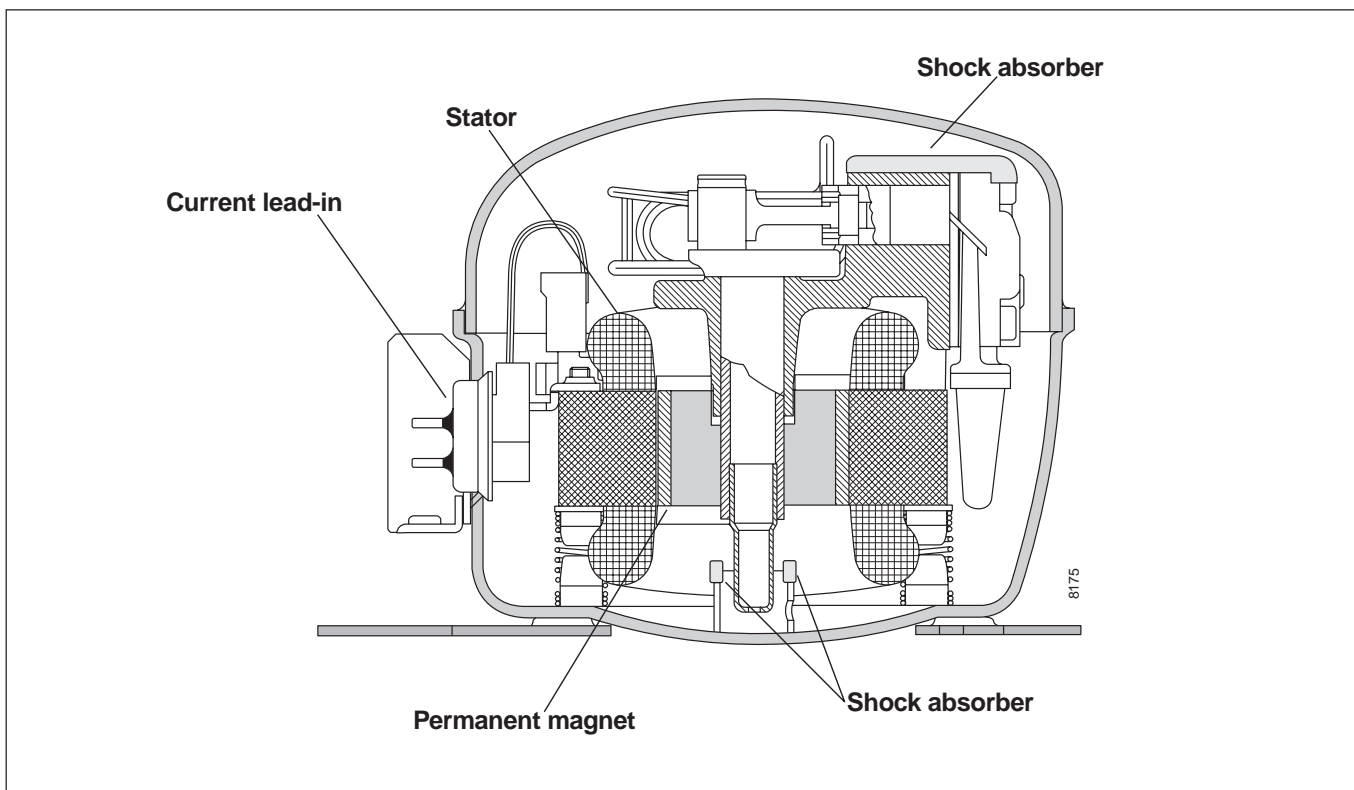

## The Danfoss product programme for the refrigeration industry contains:

### Compressors for Refrigeration and Air Conditioning

A wide range of hermetic reciprocating compressors and scroll compressors as well as aircooled condensing units. The product range is applied in air conditioning units, water chillers and commercial refrigeration systems.



### Compressors for Refrigerators and Freezers

Hermetic compressors and fan-cooled condensing units for household refrigeration units such as refrigerators and freezers, and for commercial installations such as sales counters and bottle coolers. Compressors for heating pump systems. 12 and 24 V compressors for refrigerators and freezers in commercial vehicles, buses, and boats.



### Appliance Controls

For the regulation of refrigeration appliances and freezers Danfoss supply a CFC-free product range of electromechanical thermostats for refrigerators and electromechanical thermostats for refrigerators and freezers produced according to customer specification; Hermetic valves for refrigerator/freezer combinations and for energy saving applications; Service thermostats – for all refrigerating and freezing appliances.



### Refrigeration and Air Conditioning Controls

With our full product range we cover all the requirements for mechanical and electronically controlled refrigeration systems. The functions cover: control, safety, system protection and monitoring. Our products are applied for all commercial- and industrial refrigeration applications as well as for air conditioning.

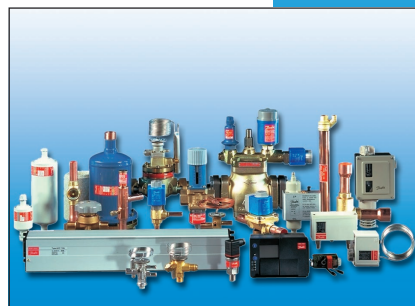

[www.danfoss.com/compressors](http://www.danfoss.com/compressors)

Danfoss can accept no responsibility for possible errors in catalogues, brochures and other printed material. Danfoss reserves the right to alter its products without notice. This also applies to products already on order provided that such alterations can be made without subsequential changes being necessary in specifications already agreed. All trademarks in this material are property of the respective companies. Danfoss and the Danfoss logotype are trademarks of Danfoss A/S. All rights reserved.