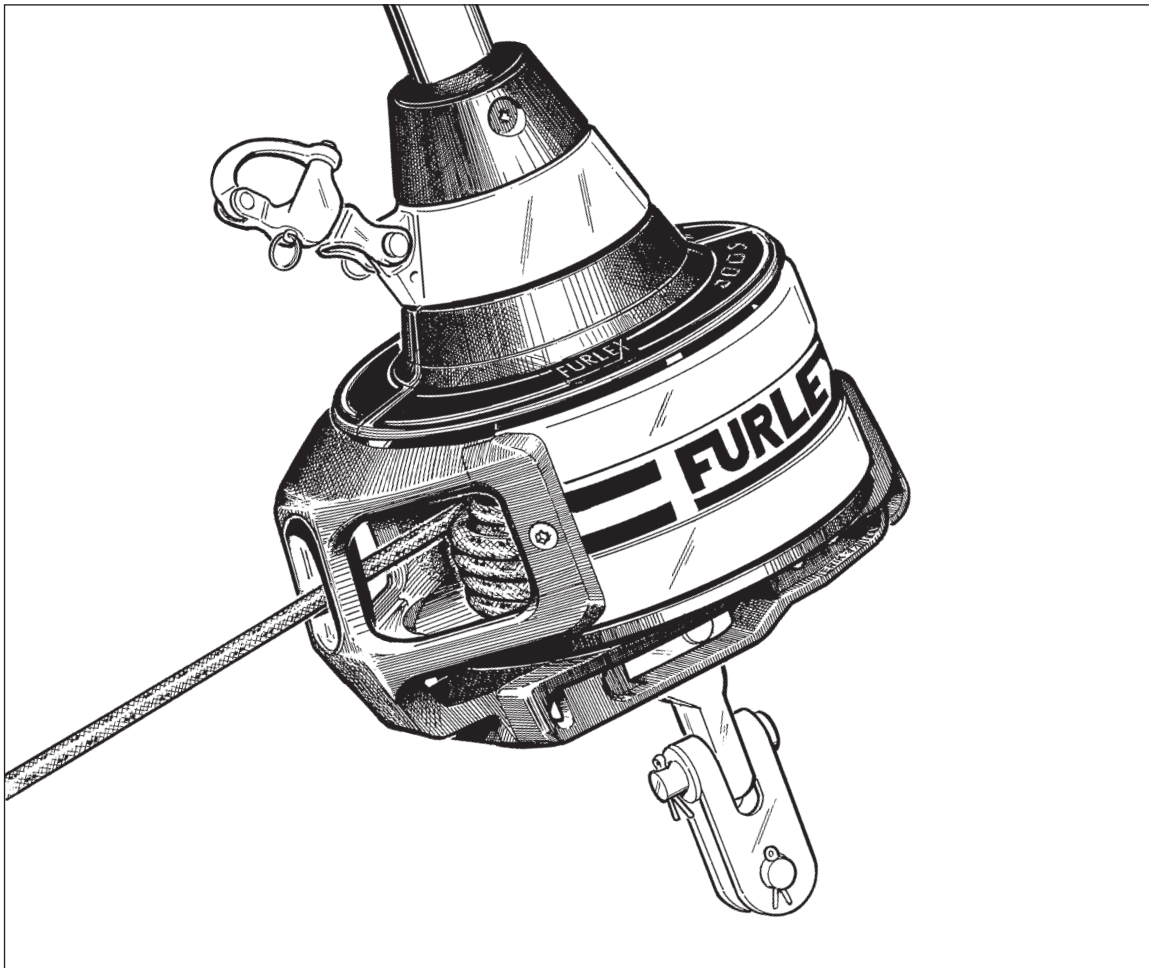


FURLEX

SELDÉN


Manual Furlex *200 S & 300 S*



SELDÉN

1 Introduction

1.1 The manual

- To derive the maximum benefit and enjoyment from your Furlex-system, we recommend that you study this manual carefully.
- The manual is divided into two sections, one dealing with **ASSEMBLY** and one with **OPERATION**. Each section contains references to the other. It is very important to read and note these cross references.
- All safety-related information is indicated by the following symbol: 
- The manual covers two different Furlex sizes, 200 S and 300 S. The model designation can be found on the line drum top.
- Furlex is specified and manufactured using Metric dimensions. To assist owners unfamiliar with this system, the approximate equivalent Imperial dimensions are given in brackets.
- The screws used for the halyard swivel and lower bearing assembly have a Torx socket. The Torx type socket has an excellent grip but is not yet in common use. A Torx spanner set is included with the Furlex. The Torx socket sizes are:

Screw Size	Torx Socket
M5	T 25
M6	T 30
M8	T 40




Fig: 1.1.a



This information must be followed to avoid damage to the system and the risk of personal injury. The 5-year guarantee on the Furlex-system is only valid if the system is assembled and operated correctly according to the manual.



PLEASE read the entire manual prior to assembly!

Seldén Mast AB guarantees the Furlex-system for 5 years. The guarantee covers faults arising from defective design, materials or workmanship.

The guarantee is only valid if the Furlex-system is assembled, operated and maintained in accordance with this manual and is not subjected to loads in excess of those indicated in the brochure and instructions.

If the system is repaired by anyone other than Seldén Mast AB or one of our authorized dealers, the guarantee ceases to be valid.

Seldén Mast AB reserves the right to alter the content and design without prior warning.

Contents

	<i>Page</i>		<i>Page</i>
1 Introduction		OPERATING MANUAL	32
1.1 <i>The manual</i>	2	10 Halyard routing	
1.2 <i>Product information</i>	4	10.1 <i>Summary</i>	33
ASSEMBLY		10.2 <i>Halyard sheave box</i>	34
2 Checklist		10.3 <i>Spinnaker halyard</i>	34
2.1 <i>Furlex box</i>	6	11 Sailing with Furlex	
2.2 <i>Foil pack</i>	8	11.1 <i>To hoist the sail</i>	35
2.3 <i>Tools</i>	8	11.2 <i>Unfurling the sail</i>	36
3 Assembly preparations		11.3 <i>Furling the sail</i>	37
3.1 <i>Forestay attachment - guiding principle</i>	9	12 Reefing	
3.2 <i>Mast attachment</i>	9	12.1 <i>Free turn</i>	38
3.3 <i>Deck attachment</i>	9	12.2 <i>Reefing under sail</i>	38
3.3.1 <i>Dimensions of lower bearing assembly</i>	10	12.3 <i>Setting a reefed sail from the furled position</i>	39
3.3.2 <i>Dimensions of top eye terminal</i>	10	12.4 <i>Adjusting the sheeting position</i>	39
3.3.3 <i>Table of measurements for toggles</i>	11	13 Furlex for racing	40
3.4 <i>Assembly below deck</i>	12	14 Adjusting the forestay length	
3.5 <i>Calculating the length of the forestay wire</i>	13	14.1 <i>Furlex with rigging screw</i>	41
3.5.1 <i>Table 1: Calculation of forestay wire length</i>	13	14.1.1 <i>Rigging Screw adjustment</i>	42
3.6 <i>Calculating the length of the luff extrusion</i>	14	14.2 <i>Furlex without rigging screw</i>	42
3.6.1 <i>Table 2: Calculation of luff extrusion length</i>	14	15 Maintenance of the Furlex-system	
4 Assembly of the Furlex-system		15.1 <i>Lubricating the lower bearing assembly</i>	43
4.1 <i>Assembly of the luff section</i>	16	15.2 <i>Lubricating the halyard swivel</i>	43
4.2 <i>Fitting the wire terminal (or rigging screw)</i>	18	15.3 <i>Cleaning the Furlex</i>	44
4.2.1 <i>Without rigging screw/With rigging screw</i>	18	15.4 <i>Storage</i>	44
4.3 <i>Fitting the line drum and line guide</i>	21	16 Rigging	
5 Halyard routing		16.1 <i>Fitting the Furlex on a stepped mast</i>	45
5.1 <i>Halyard leads</i>	23	16.2 <i>Stepping the mast with Furlex fitted</i>	46
5.2 <i>Halyard sheave box</i>	24	17 Dismantling	
5.2.1 <i>Sheave boxes</i>	24	17.1 <i>Halyard swivel</i>	46
5.3 <i>Spinnaker halyard</i>	24	17.2 <i>Sail feeder</i>	46
5.4 <i>Fitting the halyard lead</i>	24	17.3 <i>Lineguide</i>	47
6 Furling line arrangement		17.4 <i>Line drum</i>	48
6.1 <i>Functional description</i>	26	17.5 <i>Lower bearing assembly</i>	48
6.2 <i>Winding the line onto the drum</i>	26	17.6 <i>Wire terminal</i>	49
6.3 <i>Routing of the furling line</i>	27	17.7 <i>Luff extrusion system</i>	49
6.4 <i>200 S: Fitting the stanchion blocks</i>	28	18 Trouble shooting	50
6.5 <i>300 S: Fitting the stanchion blocks</i>	28	19 Checklist	
7 The Sail		19.1 <i>Points to check before sailing</i>	52
7.1 <i>Adapting the sail to the Furlex-system</i>	29		
7.1.1 <i>Table of sail measurements</i>	30		
7.2 <i>Sail shape</i>	30		
7.3 <i>Determining the length of the pendant</i>	31		

1.2 Product information

When the original Furlex was introduced in 1983, it was not a pioneering project. The design included features which improved on other manufacturers' products to increase performance, function and reliability. The first systems sold are still functioning well, providing ample proof of the design's effectiveness and long-term staying power. Furlex quickly became the market leader, a position it still occupies today. Our success can also be put down to how we select a system for a specific yacht. First we calculate the boat's righting moment, which is a function of its displacement, ballast, beam and draft. Then we use righting moment in combination with the rig type to calculate its power when sailing, and the likely loads on the Furlex-system.

Furlex is only sold through authorized local dealers who are able to cover all service requirements for the customer, including assistance with assembly, the modification of sails or the production of new sails.

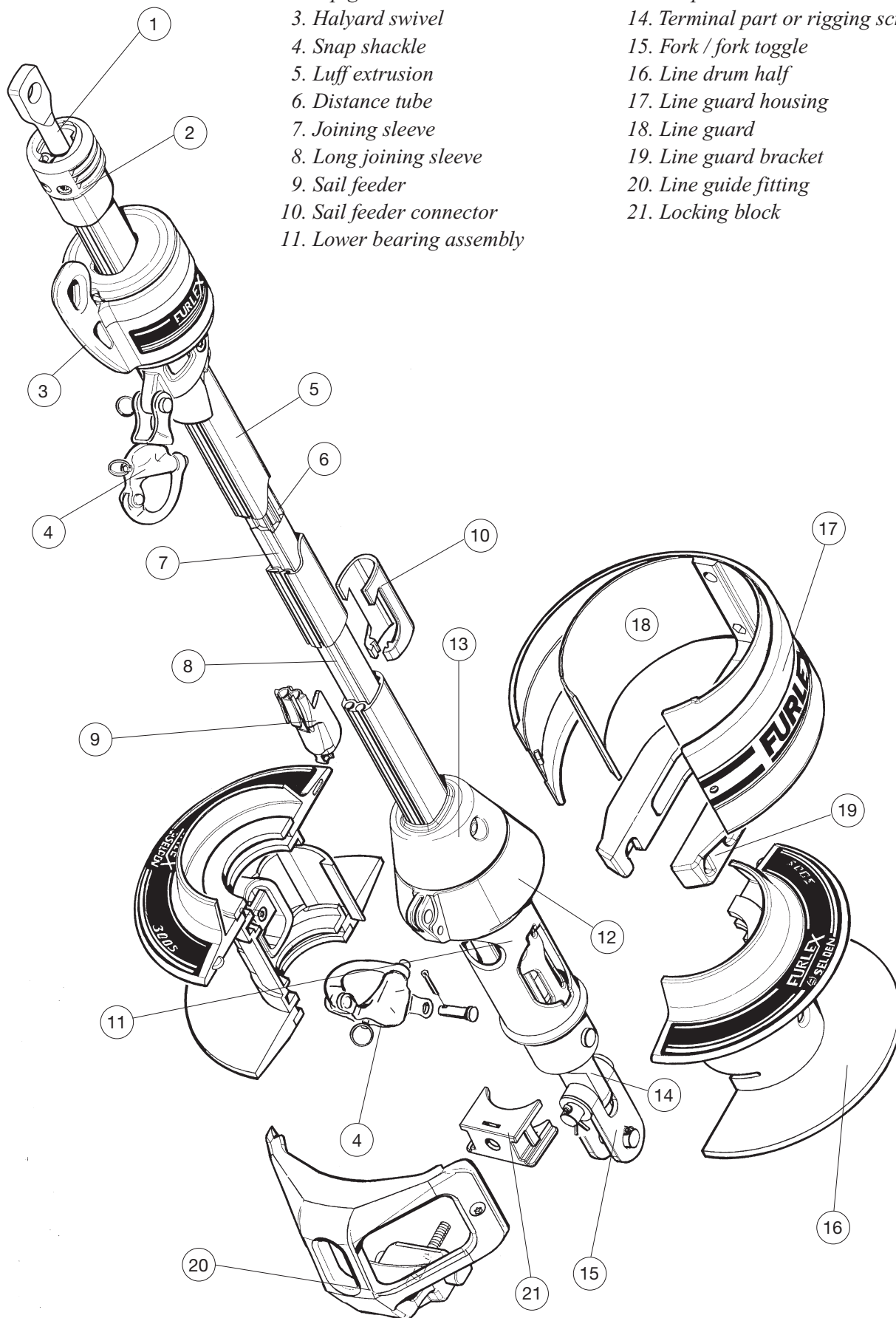
This new Furlex model range incorporates improvements based on our extensive experience, and represents the very latest development of the jib furling and reefing concept.

- Furlex is supplied as a complete assembly kit containing all the components required.
- The ball-bearing system of the halyard swivel features a load distribution facility, a unique patented system which distributes loads over the entire ball race. This permits smoother furling and considerably reduces bearing wear.
- Furlex can be supplied with an optional integral rigging screw.
- The Furlex luff section has the same dimensions over its whole length. The entire luff is furled in an even roll, right down to the tack of the sail. This is a requirement for satisfactory sail shape when reefed.
- The tack ring's "free turn" flattens out the sail, promoting an efficient shape when reefed.
- Furlex is suited to both cruising and racing. The line drum and line guide are easy to remove if you want to utilize the entire forestay length for racing.
- The luff section has two luff grooves, allowing two jibs to be goose-winged when running down-wind and facilitating fast sail changes for racing yachtsmen.
- The prefeeder is to help when hoisting the sail.
- The aluminium extrusion is insulated from the forestay over its whole length. The extrusion joining sleeves are also insulated internally to prevent wear and corrosion.
- The line guide fitting centres the line as it is wound onto the drum, and the flexible internal line guard maintains light pressure on the line to ensure even distribution on the drum.
- Furlex is manufactured by Seldén Mast, the world's leading manufacturer of masts and rigging systems.



Follow the instructions carefully when fitting.

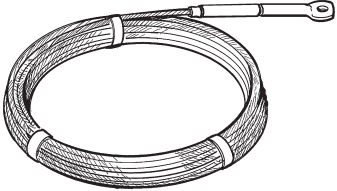
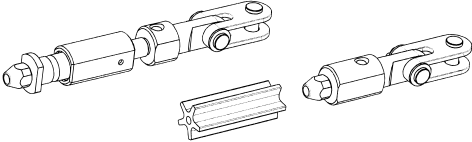
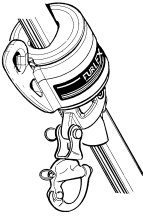
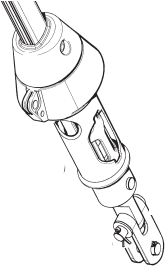
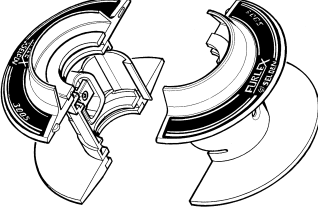

- | | |
|----------------------------|------------------------------------|
| 1. Forestay /eye terminal | 12. Tack ring |
| 2. Top guard | 13. Adapter |
| 3. Halyard swivel | 14. Terminal part or rigging screw |
| 4. Snap shackle | 15. Fork / fork toggle |
| 5. Luff extrusion | 16. Line drum half |
| 6. Distance tube | 17. Line guard housing |
| 7. Joining sleeve | 18. Line guard |
| 8. Long joining sleeve | 19. Line guard bracket |
| 9. Sail feeder | 20. Line guide fitting |
| 10. Sail feeder connector | 21. Locking block |
| 11. Lower bearing assembly | |



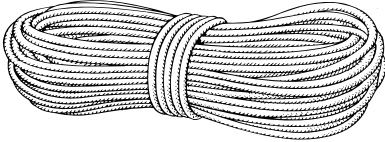
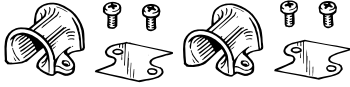

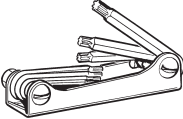
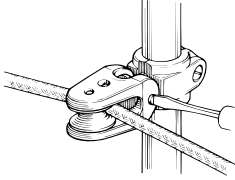
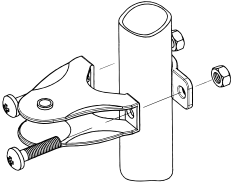
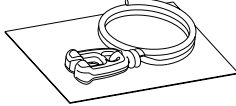


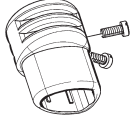



ASSEMBLY

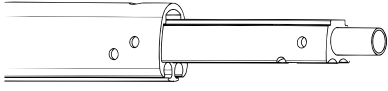

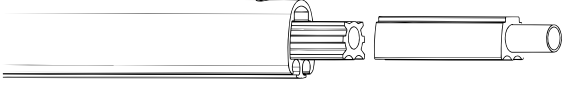
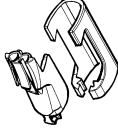
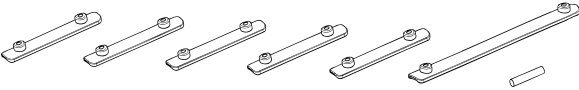
2 Checklist

2.1 Furlex box

<input type="checkbox"/> Forestay wire with top bearing	
<input type="checkbox"/> Wire terminal with distance bearing or with rigging screw function. (Depends on which type ordered.)	
<input type="checkbox"/> Halyard swivel with snap shackle	
<input type="checkbox"/> Lower bearing assembly with snap shackle	
<input type="checkbox"/> Two line drum halves (one with furling line end lock)	
<input type="checkbox"/> Line guide fitting	

<input type="checkbox"/> Line guard housing	
<input type="checkbox"/> Line guide locking block	
<input type="checkbox"/> Furling line	
<p>200 S:</p> <input type="checkbox"/> 2 halyard leads 508-159 with insulator sheets incl. 4 screws <input type="checkbox"/> Drill bit Ø 5,3 mm (7/32") <p>300 S:</p> <input type="checkbox"/> 2 halyard leads 508-128 with insulator sheets incl. 6 screws <input type="checkbox"/> Drill bit Ø 5.3 mm (7/32")	 
<input type="checkbox"/> Torx spanner set	
<p>200 S:</p> <input type="checkbox"/> 4 stanchion blocks 538-971-02	
<p>300 S:</p> <input type="checkbox"/> 4 stanchion blocks 538-210-01 + 1x 538-971-01	
<input type="checkbox"/> Prefeeder	
<input type="checkbox"/> Locking adhesive <input type="checkbox"/> Lubricating grease	 
<input type="checkbox"/> Top guard incl. 2 screws	
<input type="checkbox"/> Manuals <input type="checkbox"/> Spare parts list <input type="checkbox"/> Certificate of guarantee	

2.2 Foil pack

<input type="checkbox"/> One 1000 mm (39 3/8") luff extrusion with long joining sleeve.	
<input type="checkbox"/> One 2000 mm (78 3/4") luff extrusion with distance tube.	
<input type="checkbox"/> 2400 mm (94 1/2") luff extrusions with distance tube + joining sleeve (number dependent on length ordered.)	
<input type="checkbox"/> Sail feeder (sail feeder + sailfeeder connector.)	
<input type="checkbox"/> One short connecting plate for each 2400 mm (94 1/2") luff extrusion <input type="checkbox"/> One long connecting plate (for sail feeder) <input type="checkbox"/> One locking pin 3 x 25 (1/8" x 1") for 1000 mm (39 3/8") luff extrusion	

2.3 Tools

Tools needed for assembly:

- Screwdriver
- Hacksaw
- 2 adjustable spanners
- Pair of pliers ("Polygrip")
- Adhesive tape
- File
- Marker pen (water-proof)
- Torx spanners (included in Furlex package)
- Steel measuring tape (20 m) (60'7")
- Knife

For halyard leads:

- Heavy-duty Philips screwdriver
- Drill
- Drill bit Ø 5.3 mm (7/32") (included in package)

3 Assembly preparations

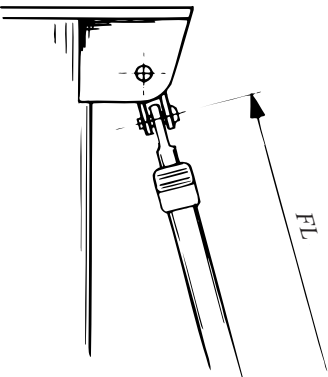
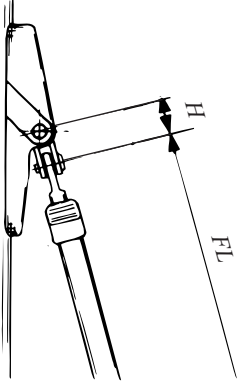
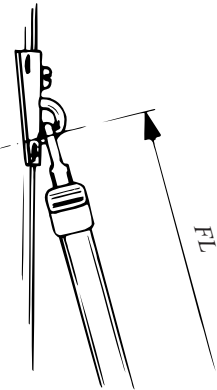
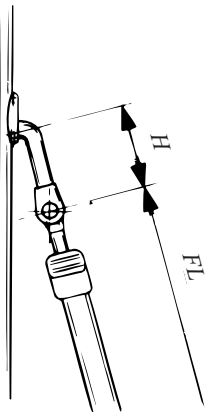
3.1 Forestay attachment - guiding principle



The guiding principle is that the forestay connections should allow sufficient articulation in all directions. In most cases a toggle should be fitted between the Furlex stay and the forestay attachments.

3.2 Mast attachment

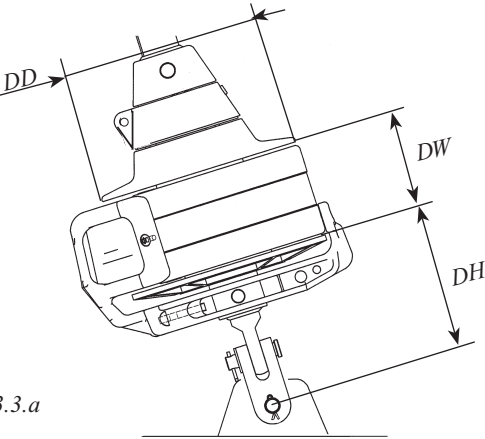
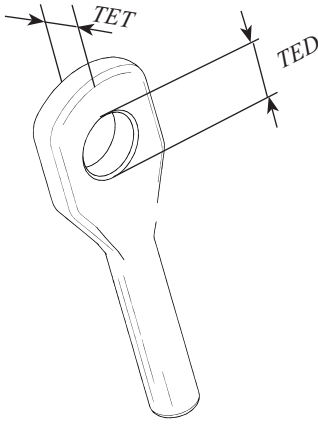
Some Seldén forestay attachment options are shown below, illustrating the rules and exceptions. For H dimensions, see Table 3.3.3.

<p><i>Fig: 3.2.a</i></p>  <p>Forestay attachment on masthead rigs: Always connect the stay with a toggle to give full articulation.</p>	<p><i>Fig: 3.2.b</i></p>  <p>Forestay attachment on fractional rigs, Seldén type: 505-018 \varnothing 6 & 7 mm wire: Connect with an eye/fork-toggle. 505-020 \varnothing 8 & 10 mm wire: Connect to existing toggle.</p>
<p><i>Fig: 3.2.c</i></p>  <p>Forestay attachment, Seldén type: O-35 (517-905) & O-50 (517-911) Connect directly to fitting.</p>	<p><i>Fig: 3.2.d</i></p>  <p>Forestay attachment "T-terminal" type: Fit a T/fork toggle according to the table 3.3.3.</p>

3.3 Deck attachment

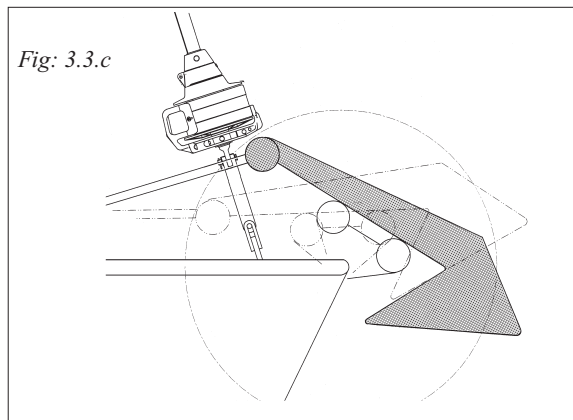
The lower end of the Furlex-system is fitted with a fork toggle as standard. This can normally be attached directly to the boat's forestay fitting at the stemhead.


Check that the lower bearing assembly and line guide do not interfere with the pulpit, navigation lights or other deck fittings.


3.3.1 Dimensions of lower bearing assembly (mm)				3.3.2 Dimensions of top eye terminal		
 <p>Fig: 3.3.a</p>				 <p>Fig: 3.3.b</p>		
Furlex Series	DD	DH	-DW	Wire Dim.	TED	TET
200 S	Ø 186 (7 1/3")	120 (4 3/4")	95 (3 3/4")	ø 6 (1/4")	12,2 (1/2")	6 (1/4")
				ø 7 (9/32")	13,5 (9/16")	7 (9/32")
				ø 8 (5/16")	16,5 (5/8")	10 (3/8")
300 S	Ø 216 (8 1/2")	150 (5 7/8")	115 (4 1/2")	ø 8 (5/16")	16,5 (5/8")	10 (3/8")
				ø 10 (3/8")	16,5 (5/8")	10 (3/8")

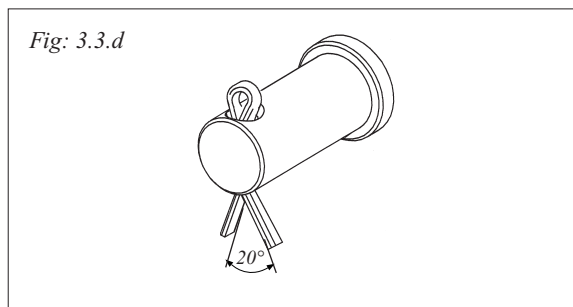
If the boat is fitted with a bow anchor, it may be necessary to permanently raise the lower bearing assembly to give the crew sufficient space for anchor work. A selection of extension links are available (see Table 3.3.3).

If the lower bearing assembly is raised by means of an extension link, a Furlex toggle or similar toggle with the same function should be fitted between the link and the boat's forestay attachment.



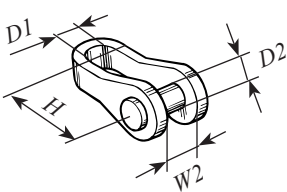
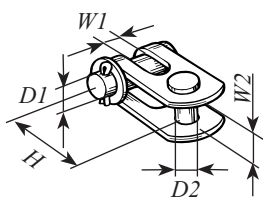
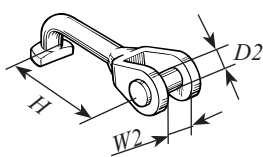
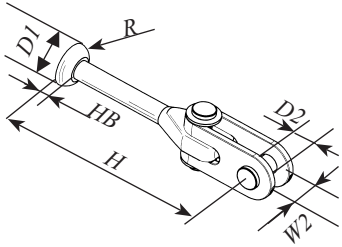
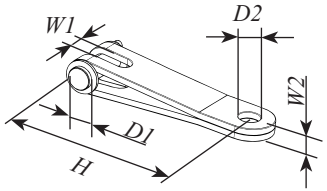
 **An extension link does not provide the necessary flexibility. It must always have a toggle between it and the boat's forestay attachment.**

 **Take care to ensure that the toggle split pins are secured as per Figure 3.3.d after fitting.**



3.3.3 Table of measurements for toggles

(Toggles available from your Furllex dealer)

Toggle type		Forestay Dimensions				
		Ø 6 (1/4")	Ø 7 (9/32")	Ø 8 (5/16")	Ø 10 (3/8")	
Eye / fork toggle  <i>Fig: 3.3.e</i>	Article no.	174-104	174-105	174-106	174-107	
	Length (H)	40 (1 1/2")	45 (1 3/4")	50 (2")	65 (2 1/2")	
	Ø Eye (D1)	11 (7/16")	13 (1/2")	16 (5/8")	16 (5/8")	
	Ø Clevis pin (D2)	11 (7/16")	13 (1/2")	15.8 (5/8")	15.8 (5/8")	
	Fork width (w2)	12 (1/2")	12 (1/2")	12 (1/2")	20 (3/4")	
Fork / Fork toggle  <i>Fig: 3.3.f</i>	Article no.	517-046-02	517-047-02	517-048-02	517-060-04	
	Length (H)	40 (1 1/2")	40 (1 1/2")	50 (2")	55 (2 3/16")	
	Ø Clevis pin (D1)	12 (1/2")	12 (1/2")	14 (9/16")	16 (5/8")	
	Fork width (w1)	11 (7/16")	11 (7/16")	14 (9/16")	14 (9/16")	
	Ø Clevis pin (D2)	10 (3/8")	12 (1/2")	14(9/16")	16 (5/8")	
	Fork width (w2)	11 (7/16")	12,5 (1/2")	15,5 (5/8")	16 (5/8")	
T / fork toggle  <i>Fig: 3.3.g</i>	Article no.	174-122	174-123	174-124	-	
	Length (H)	80 (3 1/4")	90 (3 1/2")	100 (4")	-	
	Ø Clevis pin (D2)	11 (7/16")	13 (1/2")	15.8 (5/8")	-	
	Fork width (w2)	12 (1/2")	14 (9/16")	16 (5/820")	-	
Stemball / Eye toggle with Fork / fork toggle  <i>Fig: 3.3.h</i>	Article no.	517-066-01	517-067-01	517-097-01	517-068-01	517-068-02
	Length (H)	152 (6")	157 (6 1/4")	153 (6")	197 (7 3/4")	202 (8")
	Ø Stemball (D1)	26 (1 1/32")	34 (1 11/32")	26 (11/32")	34 (1 11/32")	34 (1 11/32")
	Height (HB)	8 (5/16")	9 (3/8")	11 (7/16")	9 (3/8")	9 (3/8")
	Radius (R)	10 (3/8")	15 (9/16")	13 (1/2")	15 (9/16")	15 (9/16")
	Ø Clevis pin (D2)	10 (3/8")	12 (1/2")	12 (1/2")	16 (5/8")	16 (5/8")
	Fork width (w2)	11 (7/16")	12,5 (1/2")	12,5 (1/2")	15,5 (5/8")	16 (5/8")
Eye / fork Extension link  <i>Fig: 3.3.i</i>	Article no.	517-063-01	517-063-01	517-062-01	517-062-01	
	Length (H)	90 (3 9/16")	90 (3 9/16")	130 (5")	130 (5")	
	Ø Clevis pin (D1)	12 (1/2")	12 (1/2")	16 (5/8")	16 (5/8")	
	Fork width (w1)	11 (7/16")	11 (7/16")	14 (9/16")	14 (9/16")	
	Ø Eye (D2)	12 (1/2")	12 (1/2")	16,5 (5/8")	16,5 (5/8")	
	Gauge (w2)	6 (1/4")	6 (1/4")	10 (3/8")	10 (3/8")	

3.4 Assembly below deck

The lower bearing assembly can be fitted below deck inside an anchor well.

The advantage is that the sail's luff length is maximized and the access around the forestay is improved.

The disadvantage is a more complicated route for the furling line, increasing furling resistance. The diagrams below illustrate various methods of installation.

- For the furling line to be wound evenly onto the line drum, the first turning point must be at least 300 mm (12") away.
- The tack should be located as close to deck level as possible.
- Regardless of which option is chosen, the Furlex-system must always be kept clear of the deck well's inside surfaces.
- Avoid routing the line through an integral deck conduit, as this will increase the friction on the furling line.
- Use a large ball-bearing block to minimize friction losses.
- The anchor well must be well drained.



To avoid damage to the Furlex-system and the boat, the system must never be allowed to come into contact with the edge of the deck or well when sailing.

Top edge of drum at deck level.

Large deck hole required for line drum.
Furling line led aft via turning block and inset deck sheave box, then aft along the deck.

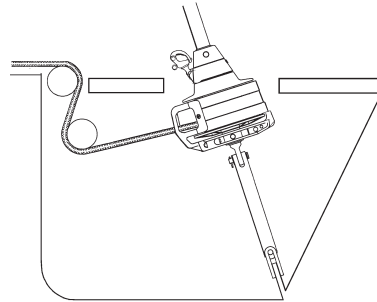


Fig: 3.4.a

Tack snap shackle at deck level.

Requires smaller hole in deck.
Furling line leads forward to an inset deck sheave box, alternatively aft via a block + deck sheave box.

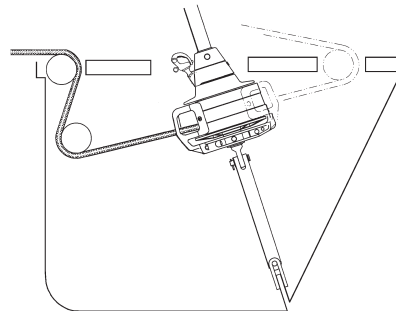


Fig: 3.4.b

Lower bearing assembly in the bottom of the anchor well. Long webbing band attached around the extrusion.

May put too much strain on the furling extrusion.

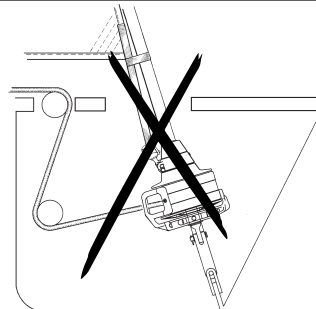


Fig: 3.4.c

Furlex fitted above deck, but with the forestay fitting in the anchor well.

Use the Furlex extension toggle. For a larger gap, use a custommade stainless steel bar or rod stay.
Short wire pennants are not recommended as forestay forces may not be distributed evenly, and wire will not resist the torque which may be produced.

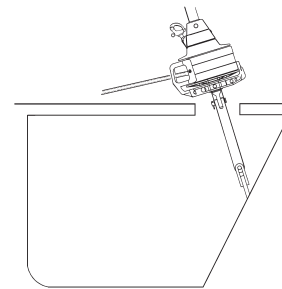


Fig: 3.4 d.

3.5 Calculating the length of the forestay wire

1. Determine the rake of the mast with the fore-/backstay tensioned.
2. Slacken the **backstay** as much as possible, but make sure that any rigging screw is not unscrewed so far that the threads are no longer visible "on the inside". The forestay setting should not be adjusted. If there is insufficient adjustment in the backstay, and the forestay must be adjusted to allow removal, first mark its thread with adhesive tape.
3. Pull the masthead forward using the genoa halyard. Secure the halyard using a "D" shackle or tie it to a strong deck fitting. For safety reasons, do not use the halyard snap shackle.



Always use a strong "D" shackle or tie the halyard !

4. Take down the forestay. If it was slackened, adjust the rigging screw back to the tape marks.
5. Measure the forestay length (FL) **with just enough tension to keep it straight**.
6. Enter the measurement in "Table 1" below, under the heading "Your forestay", in the row marked FL.
7. Calculate the new wire length WL in Table 1. Refer to the column marked "example" to see how this is done.

3.5.1 Table1: Calculation of forestay wire length		Your forestay	Example (200 S/Ø8) with rigging screw 50% extended															
FL	Existing forestay length (FL), including rigging screw (See Fig: 3.5.a)		13.000															
T	Deduction for lower wire terminal: <table border="1" style="width: 100%; border-collapse: collapse;"> <thead> <tr> <th></th> <th>Without rigging screw:</th> <th>With rigging screw:</th> </tr> </thead> <tbody> <tr> <td rowspan="3">200 S</td> <td>Ø6 mm wire: 110 mm(4 5/16")</td> <td>Ø6 mm wire: 200 mm(7 7/8")</td> </tr> <tr> <td>Ø7 mm wire: 110 mm(4 5/16")</td> <td>Ø7 mm wire: 200 mm(7 7/8")</td> </tr> <tr> <td>Ø8 mm wire: 110 mm(4 5/16")</td> <td>Ø8 mm wire: 195 mm(7 3/4")</td> </tr> <tr> <td rowspan="2">300 S</td> <td>Ø8 mm wire: 130 mm(5 1/8")</td> <td>Ø8 mm wire: 230 mm(9")</td> </tr> <tr> <td>Ø10 mm wire: 130 mm(5 1/8")</td> <td>Ø10 mm wire: 235 mm(9 1/4")</td> </tr> </tbody> </table>		Without rigging screw:	With rigging screw:	200 S	Ø6 mm wire: 110 mm(4 5/16")	Ø6 mm wire: 200 mm(7 7/8")	Ø7 mm wire: 110 mm(4 5/16")	Ø7 mm wire: 200 mm(7 7/8")	Ø8 mm wire: 110 mm(4 5/16")	Ø8 mm wire: 195 mm(7 3/4")	300 S	Ø8 mm wire: 130 mm(5 1/8")	Ø8 mm wire: 230 mm(9")	Ø10 mm wire: 130 mm(5 1/8")	Ø10 mm wire: 235 mm(9 1/4")	-	- 195
	Without rigging screw:	With rigging screw:																
200 S	Ø6 mm wire: 110 mm(4 5/16")	Ø6 mm wire: 200 mm(7 7/8")																
	Ø7 mm wire: 110 mm(4 5/16")	Ø7 mm wire: 200 mm(7 7/8")																
	Ø8 mm wire: 110 mm(4 5/16")	Ø8 mm wire: 195 mm(7 3/4")																
300 S	Ø8 mm wire: 130 mm(5 1/8")	Ø8 mm wire: 230 mm(9")																
	Ø10 mm wire: 130 mm(5 1/8")	Ø10 mm wire: 235 mm(9 1/4")																
H	If links or extra toggles are to be used, deduct this length (H) from FL. (See table 3.3.3.)																	
WL	Cutting measurement. The new forestay wire is to be <u>marked</u> at this point.	=	= 12.805															

3.6 Calculating the length of the luff extrusion

1. Insert the length of the new forestay wire (WL) as calculated in "Table 1" into "Table 2", in the row marked WL.
2. Calculate the number of full length extrusions and the length of the top extrusion.

3.6.1 Table 2: Calculation of luff extrusion length		Your extrusion	Example (200 S/Ø8) with rigging screw															
WL	Length of new forestay wire (as per Table 1)		12.805															
A+B	Fixed deduction (A+B): <table border="1" style="margin: 5px auto; width: 80%;"> <thead> <tr> <th></th> <th>Without rigging screw:</th> <th>With rigging screw:</th> </tr> </thead> <tbody> <tr> <td rowspan="3">200 S</td> <td>Ø 6 mm wire: 1310 mm (51 1/2")</td> <td>Ø 6 mm wire: 1230 mm (48 7/16")</td> </tr> <tr> <td>Ø 7 mm wire: 1310 mm (51 1/2")</td> <td>Ø 7 mm wire: 1230 mm (48 7/16")</td> </tr> <tr> <td>Ø 8 mm wire: 1310 mm (51 1/2")</td> <td>Ø 8 mm wire: 1230 mm (48 7/16")</td> </tr> <tr> <td rowspan="2">300 S</td> <td>Ø 8 mm wire: 1380 mm (54 5/16")</td> <td>Ø 8 mm wire: 1280 mm (50 3/8")</td> </tr> <tr> <td>Ø 10 mm wire: 1380 mm (54 5/16")</td> <td>Ø 10 mm wire: 1280 mm (50 3/8")</td> </tr> </tbody> </table>		Without rigging screw:	With rigging screw:	200 S	Ø 6 mm wire: 1310 mm (51 1/2")	Ø 6 mm wire: 1230 mm (48 7/16")	Ø 7 mm wire: 1310 mm (51 1/2")	Ø 7 mm wire: 1230 mm (48 7/16")	Ø 8 mm wire: 1310 mm (51 1/2")	Ø 8 mm wire: 1230 mm (48 7/16")	300 S	Ø 8 mm wire: 1380 mm (54 5/16")	Ø 8 mm wire: 1280 mm (50 3/8")	Ø 10 mm wire: 1380 mm (54 5/16")	Ø 10 mm wire: 1280 mm (50 3/8")	-	- 1.230
	Without rigging screw:	With rigging screw:																
200 S	Ø 6 mm wire: 1310 mm (51 1/2")	Ø 6 mm wire: 1230 mm (48 7/16")																
	Ø 7 mm wire: 1310 mm (51 1/2")	Ø 7 mm wire: 1230 mm (48 7/16")																
	Ø 8 mm wire: 1310 mm (51 1/2")	Ø 8 mm wire: 1230 mm (48 7/16")																
300 S	Ø 8 mm wire: 1380 mm (54 5/16")	Ø 8 mm wire: 1280 mm (50 3/8")																
	Ø 10 mm wire: 1380 mm (54 5/16")	Ø 10 mm wire: 1280 mm (50 3/8")																
C+D	C+D=	=	11.575															
C	Max. number of 2400 mm (94 1/2") extrusions which together are shorter than C+D: [.....ex x 2400 = C]	-	(4 extrusions) - 9.600															
D	<p style="text-align: right;">Length of top extrusion =</p> <p>The top extrusion is normally cut from the 2000 mm extrusion. Round the edges of the cut end using a file.</p> <div style="border: 1px solid black; padding: 5px; margin: 5px auto; width: 80%;"> <p>If the top extrusion is shorter than 400 mm (15 3/4"), the joint will be too near the top. In this case replace the uppermost full-length 2400 mm extrusion with the 2000 mm extrusion. In this way the joint is moved 400mm (15 3/4") down the stay. Adjust the C and D measurements as follows:</p> <p>Deduct 400 mm (15 3/4") from the C measurement. Add 400 mm (15 3/4") to the D measurement.</p> </div>	=	= 1.975															
E	<p>Cut the distance tube for the top extrusion in accordance with the following fixed deduction:</p> <table border="1" style="margin: 5px auto; width: 80%;"> <thead> <tr> <th></th> <th>Without rigging screw:</th> <th>With rigging screw:</th> </tr> </thead> <tbody> <tr> <td rowspan="3">200 S</td> <td>Ø 6 mm wire: -345 mm (13 9/16")</td> <td>Ø 6 mm wire: -365 mm (14 3/8")</td> </tr> <tr> <td>Ø 7 mm wire: -345 mm (13 9/16")</td> <td>Ø 7 mm wire: -365 mm (14 3/8")</td> </tr> <tr> <td>Ø 8 mm wire: -355 mm (14")</td> <td>Ø 8 mm wire: -380 mm (15")</td> </tr> <tr> <td rowspan="2">300 S</td> <td>Ø 8 mm wire: -335 mm (13 3/16")</td> <td>Ø 8 mm wire: -375 mm (14 3/4")</td> </tr> <tr> <td>Ø 10 mm wire: -345 mm (13 9/16")</td> <td>Ø 10 mm wire: -385 mm (15 3/16")</td> </tr> </tbody> </table> <p style="text-align: right;">Deduction: -</p> <p style="text-align: right;">Length of distance tube E = =</p>		Without rigging screw:	With rigging screw:	200 S	Ø 6 mm wire: -345 mm (13 9/16")	Ø 6 mm wire: -365 mm (14 3/8")	Ø 7 mm wire: -345 mm (13 9/16")	Ø 7 mm wire: -365 mm (14 3/8")	Ø 8 mm wire: -355 mm (14")	Ø 8 mm wire: -380 mm (15")	300 S	Ø 8 mm wire: -335 mm (13 3/16")	Ø 8 mm wire: -375 mm (14 3/4")	Ø 10 mm wire: -345 mm (13 9/16")	Ø 10 mm wire: -385 mm (15 3/16")	-	- 380 = 1.595
	Without rigging screw:	With rigging screw:																
200 S	Ø 6 mm wire: -345 mm (13 9/16")	Ø 6 mm wire: -365 mm (14 3/8")																
	Ø 7 mm wire: -345 mm (13 9/16")	Ø 7 mm wire: -365 mm (14 3/8")																
	Ø 8 mm wire: -355 mm (14")	Ø 8 mm wire: -380 mm (15")																
300 S	Ø 8 mm wire: -335 mm (13 3/16")	Ø 8 mm wire: -375 mm (14 3/4")																
	Ø 10 mm wire: -345 mm (13 9/16")	Ø 10 mm wire: -385 mm (15 3/16")																

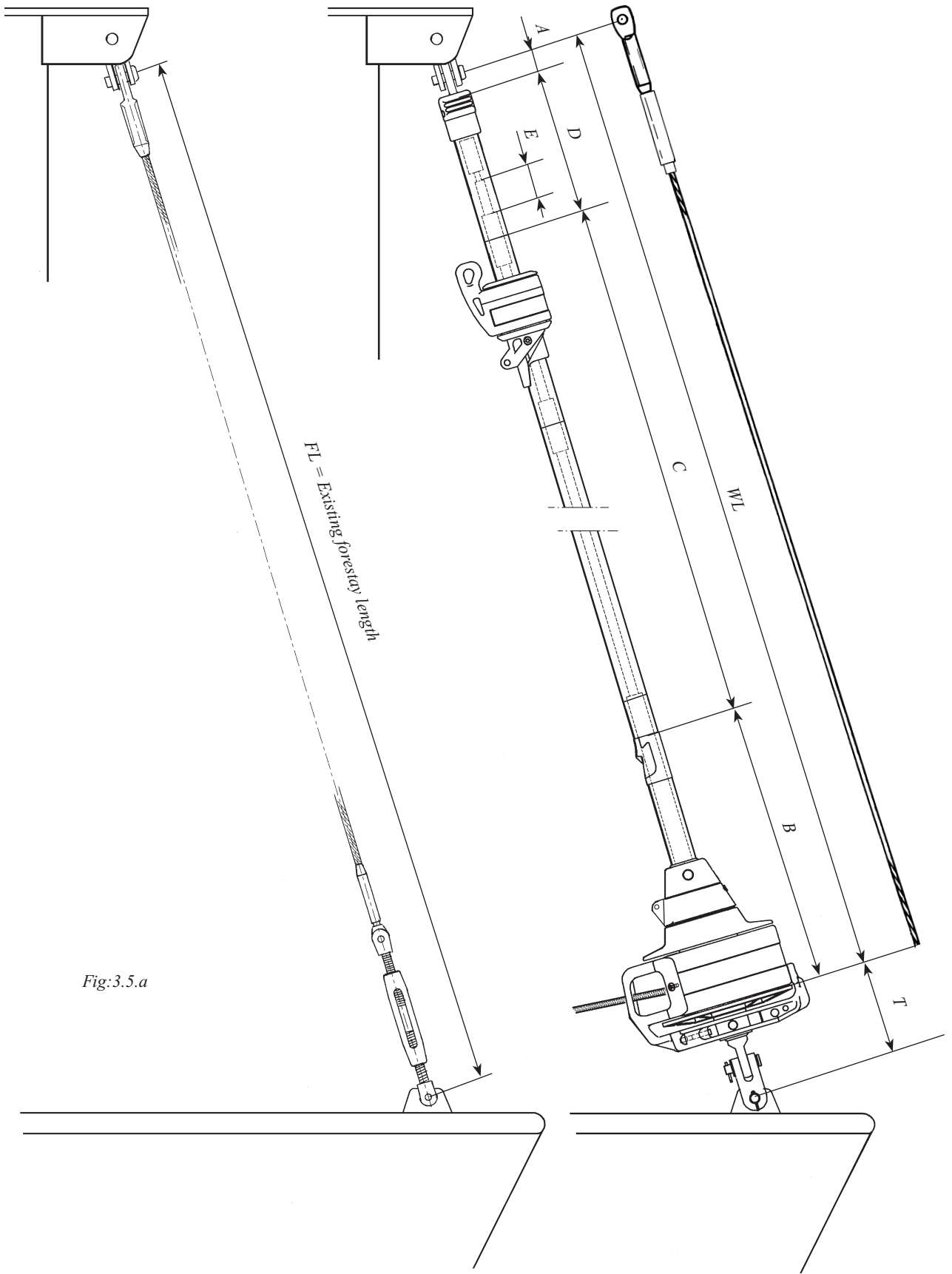


Fig:3.5.a

4 Assembly of the Furlex-system

4.1 Assembly of the luff section

Assembly should be carried out on a horizontal surface. Connect the luff extrusions one by one as follows:

1

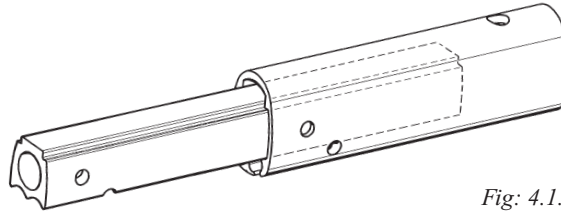


Fig: 4.1.a

The long joining sleeve must be in the 1000 mm (39 3/8") luff extrusion when commencing assembly.

2

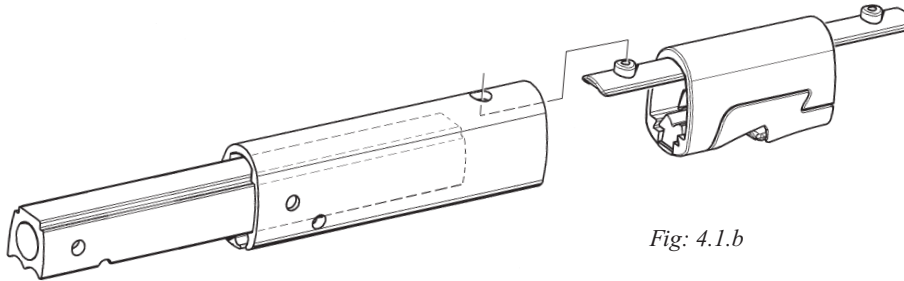


Fig: 4.1.b

Fit the long connecting plate at the same time as the sail feeder as shown in the diagram. Push the joining sleeve up so that it is flush with the top edge of the sail feeder.

3

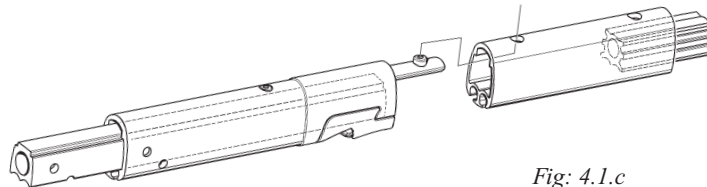


Fig: 4.1.c

Remove the 200 mm (7 3/8") joining sleeve from a 2400 mm (94 1/2") extrusion (this joining sleeve is to be used later for the 2000 mm (78 3/4") extrusion). Connect the 2400 mm (94 1/2") extrusion to the 1000 mm (39 3/8") extrusion. Push the long joining sleeve of the 1000 mm (39 3/8") extrusion into the 2400 mm (94 1/2") extrusion until it lies flush with the lower edge of the 1000 mm (39 3/8") extrusion.

4

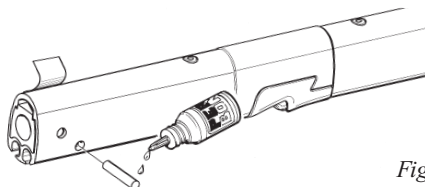


Fig: 4.1.d

Insert the locking pin together with the locking adhesive. Secure the pin with a piece of adhesive tape. (The tape is removed when the lower bearing assembly is slid on.)

Note: Do not allow locking adhesive to come into contact with the skin!

5

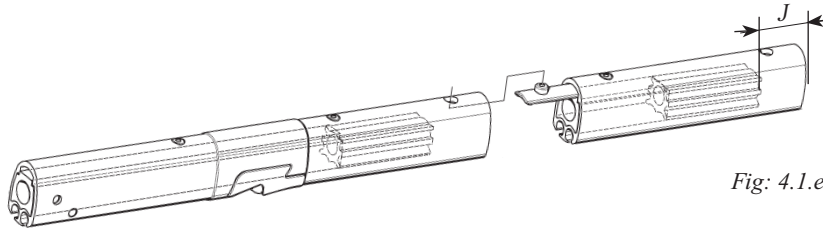


Fig: 4.1.e

Fit a joining sleeve into the next 2400 mm (94 1/2") extrusion together with a connecting plate. Connect this to the lower extrusions. Using a spare joining sleeve, push in the distance tube from the top until the lower joining sleeve touches the distance tube below the join. Check that the distance (J) between the end of the distance tube and the end of the extrusion is approximately half the length of a joining sleeve.

6

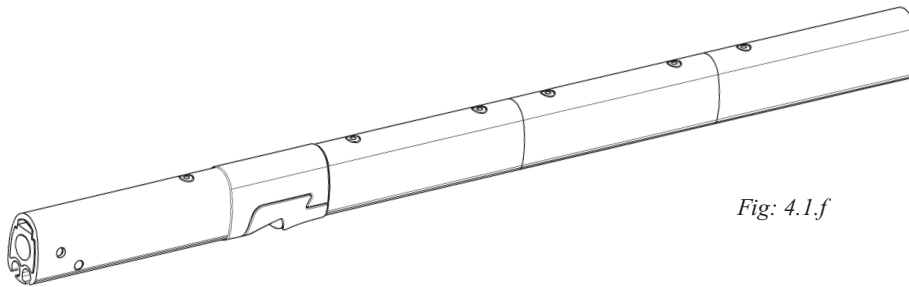


Fig: 4.1.f

Connect the remaining extrusions according to "Table 2" (3.6.1)

7

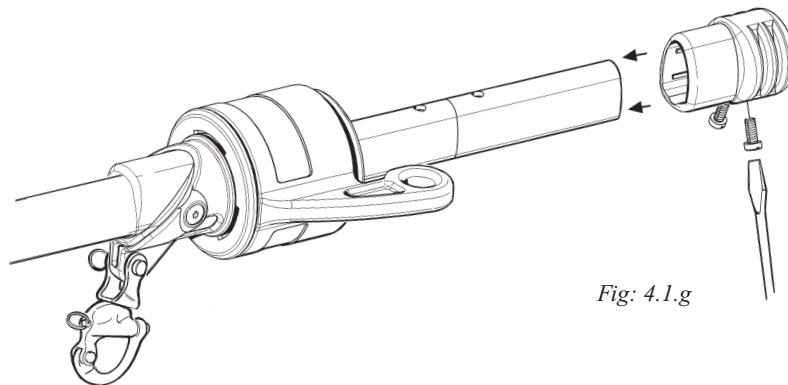


Fig: 4.1.g

Fit the halyard swivel over the top end of the extrusion, slide it down as far as the sail feeder and secure it in this position with adhesive tape. Fit the top guard and secure it with the two pre-fitted screws. Tighten the screws until they bottom, but do not over-tighten.

8

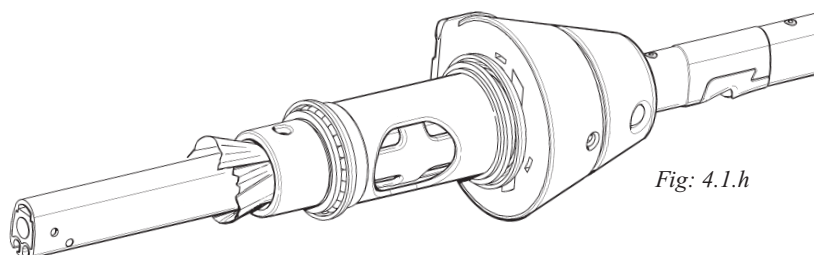


Fig: 4.1.h

Feed the adapter on to the adapter tube, cover the tube with some kind of protection and secure it to the luff section with adhesive tape.

4.2 Fitting the wire terminal (or rigging screw)

1. Stretch the Furlex wire out by hand on a flat surface.
Be careful when you open the wire coil as it may uncoil quickly.



Note: Be careful when you open the wire coil!

2. Measure the wire from the centre of the hole in the terminal end fitting. Mark the measurement WL carefully on the wire using a marker pen. (The WL measurement was calculated in "Table 1", (Chapter 3.5.1.)
3. The wire is annealed and tapered, making it easier to fit into the extrusion. **Do not cut the wire yet.**
4. Feed the wire through the luff extrusions from the top until the eye of the end fitting stops against the top guard. Secure it in this position with adhesive tape. If the wire catches inside the extrusion, turn it counter-clockwise until it passes the obstruction.
5. Put adhesive tape around the wire on both sides of the cutting mark to assist cutting. Check that the measurement between the cutting mark and the bottom edge of the 1000 mm (39 3/8") extrusion is as shown in the following table 4.2.1.

4.2.1	Without rigging screw:	With rigging screw:
200 S	Ø6 mm (1/4") wire: approx 200 mm (7 7/8")	Ø6 mm (1/4") wire: approx 140 mm (5 1/2")
	Ø7 mm (9/32") wire: approx 200 mm (7 7/8")	Ø7 mm (9/32") wire: approx 140 mm (5 1/2")
	Ø8 mm (5/16") wire: approx 200 mm (7 7/8")	Ø8 mm (5/16") wire: approx 145 mm (5 3/4")
300 S	Ø8 mm (5/16") wire: approx 240 mm (9 7/16")	Ø8 mm (5/16") wire: approx 180 mm (7 1/8")
	Ø10 mm (3/8") wire: approx 240 mm (9 7/16")	Ø10 mm (3/8") wire: approx 180 mm (7 1/8")

6. Cut the wire. Round the end of the wire using a file.

7.

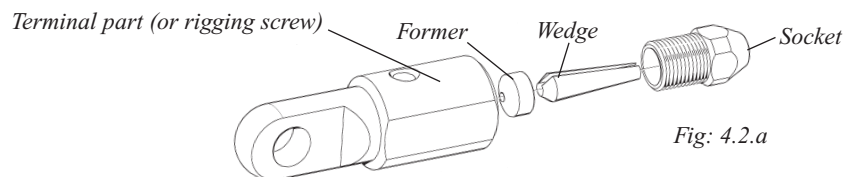


Fig: 4.2.a

Unscrew the socket, wedge and former from the terminal part (or Furlex rigging screw if to be used.)

8.

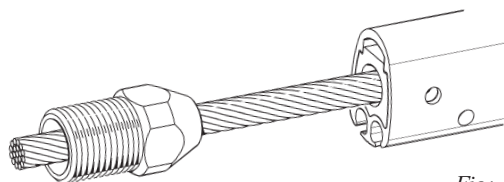
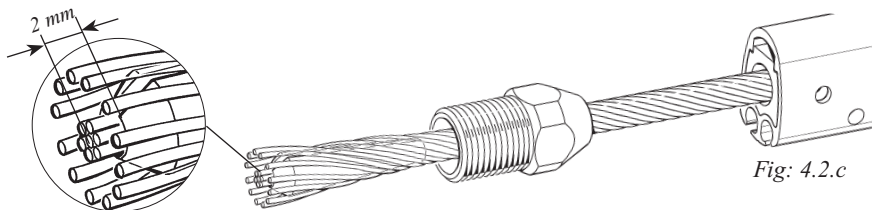


Fig: 4.2.b

Thread the socket onto the wire.

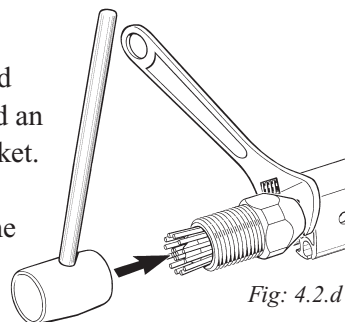
9.



Slide the wedge over the core (7 strands) of the wire . The core of the wire should protrude approx. 2 mm (3/32”) from the wedge.

10.

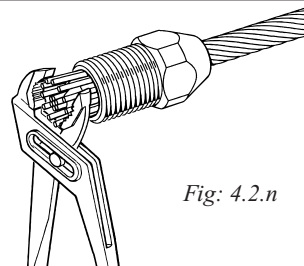
Space the outer strands of the wire evenly around the wedge and bring down the socket so that the strands are held in place. Hold an adjustable spanner between the 1000 mm extrusion and the socket. Tapping the core of the wire, locate it firmly in the socket. Check that the core of the wire protrudes approx. 2 mm from the wedge. See fig: 4.2.c.



NOTE! Check that no strands slip into the slot of the wedge.

11.

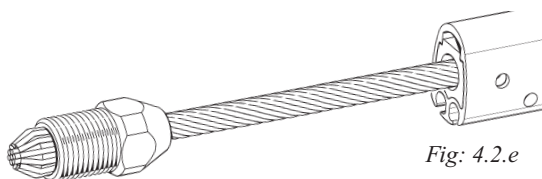
Bend the outer strands inwards a little using a pair of pliers, or tap the strands with a small hammer. In the latter case, rest the socket’s thread on a soft surface (wood or similar) to prevent damage.



12. Insert the former into the threaded hole of the terminal part (or rigging screw). Lubricate the socket’s thread with a long bead of locking adhesive. Screw the terminal part onto the socket and tighten carefully, forcing the wire further into the terminal.

13.

Unscrew and check that the outer strands are evenly distributed around the wedge. If some strands are crossed, correct their positions.

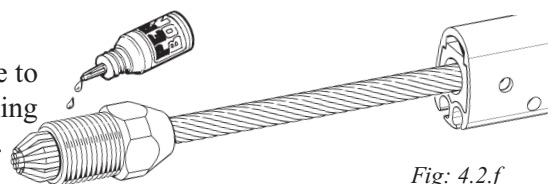


NOTE! Check that no strand has slipped into the slot of the wedge!

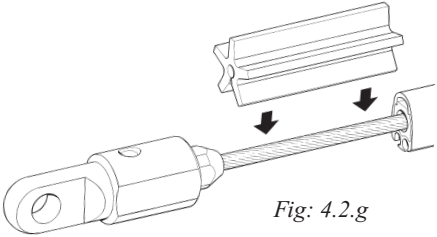
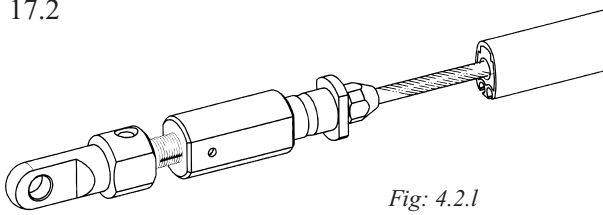
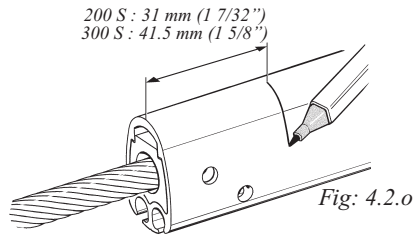
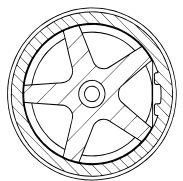
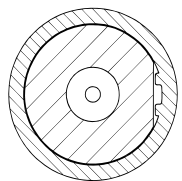
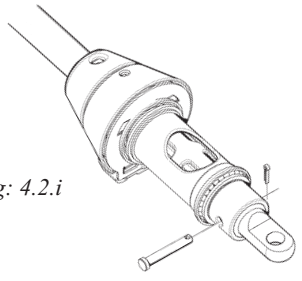
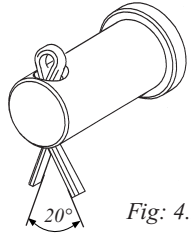
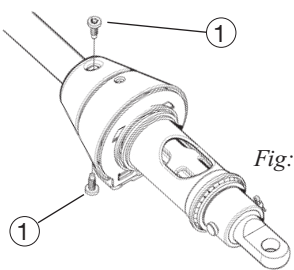
14. If assembly is unsuccessful and needs to be repeated, refer to the relevant sections of Chapter 17, ”Dismantling the Furlex”.

15.

Apply another 2 or 3 drops of the locking adhesive to the thread and screw the terminal together, tightening it firmly. The terminal is now permanently locked.



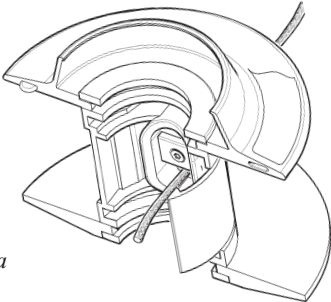
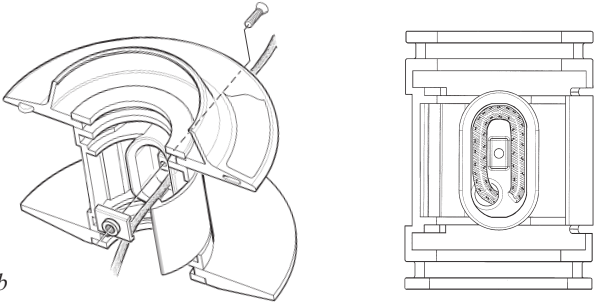
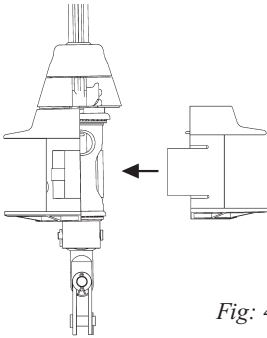
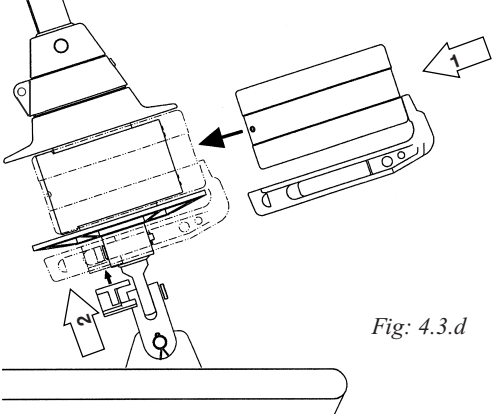
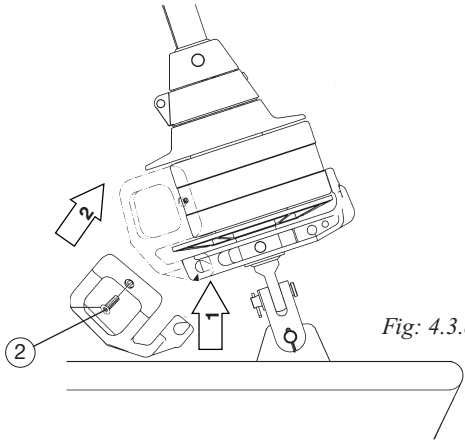
16. Check the length FL of the stay acc. "Table 1" (3.5.1) & Fig: 3.5.a. If the Furlex rigging screw is fitted, it should be 50% extended. ("Rigging screw adjustment", see table 14.1.1.)

<p>17.1</p>  <p><i>Fig: 4.2.g</i></p> <p>Terminal part: Press the spacer bush over the wire.</p>	<p>17.2</p>  <p><i>Fig: 4.2.l</i></p> <p>Rigging screw: No spacer bush.</p>
<p>17.3</p> <p>Mark the 1000 mm extrusion with a permanent marker as shown. This will assist final alignment with the lower bearing assembly.</p>  <p><i>Fig: 4.2.o</i></p>	
<p>18.1</p>  <p><i>Fig: 4.2.m</i></p> <p>Terminal part: Guide the lower bearing assembly down over the spacer bush and the terminal part. The inside of the lower bearing assembly matches the flat face on the terminal part.</p>	<p>18.2</p>  <p><i>Fig: 4.2.h</i></p> <p>Rigging screw: If a Furlex rigging screw is used, the flat faces of all three components must be aligned. As the inside of the lower bearing assembly matches the flat faces, it will securely lock the rigging screw. When fitting the Furlex, the rigging screw should be unscrewed halfway.</p>
<p>19.</p> <p>Fit the clevis pin and split pin. The shanks of the split pin are only opened approx. 20°, ensuring that the pin remains intact on disassembly and could be re-used.</p>  <p><i>Fig: 4.2.i</i></p>  <p><i>Fig: 4.2.j</i></p>	
<p>20.</p> <p>Position the extrusion so that the mark aligns with the top face of the adapter, and then carefully adjust until holes in the 1000 mm extrusion are aligned with the adapter holes. Screw the two screws ① into the adapter which connects the lower bearing assembly to the furling section. Use the Torx spanner set enclosed with the Furlex package. Apply locking adhesive on the screws. <u>Tighten the screws hard.</u></p>  <p><i>Fig: 4.2.k</i></p>	

21. We recommend fitting the Furlex-system onto the boat at this stage. (See Chapter 16, "Rigging".)

4.3 Fitting the line drum and line guide

The line drum consists of two halves. These are easier to fit after the Furlex is fitted to the boat.

<p>1.</p> <p>Feed the furling line through the hole in the line guide fitting and then through the hole in the line drum half which has a clip fitted.</p>	 <p><i>Fig: 4.3.a</i></p>
<p>2.</p> <p>Undo the clip and insert the line into the oval space as shown in the diagram. Fasten the clip securely!</p>	 <p><i>Fig: 4.3.b</i></p>
<p>3.</p> <p>Press the line drum halves together around the lower bearing assembly. Each flange must align with the oval cut-out in the lower bearing assembly. Check that both connector clips engage.</p>	 <p><i>Fig: 4.3.c</i></p>
<p>4.</p>  <p><i>Fig: 4.3.d</i></p> <p>Slide the line guard on in the direction of the clevis pin. Press the locking block in from underneath (Arrow 2) on the opposite side so that it "clips" firmly into place.</p>	<p>5.</p>  <p><i>Fig: 4.3.e</i></p> <p>Fasten the line guide fitting in the line guard and bring this up into the assembly position. Tighten the screws ② (in the line guard housing).</p>

6. Tighten the screw ③ lightly.

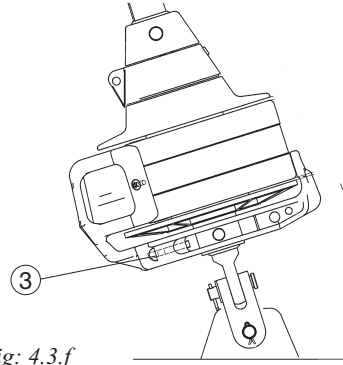


Fig: 4.3.f

7.

Adjust the line guide vertically so that it is midway between the line drum flanges. If the casing or line guard come into contact with the line drum flanges, unnecessary friction will be caused.

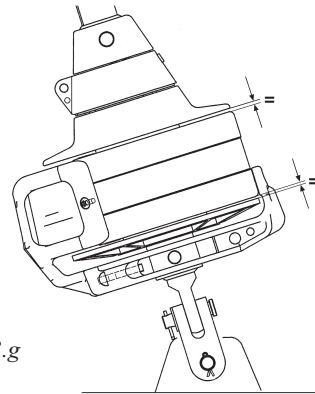


Fig: 4.3.g

8.

Adjust the alignment of the line guide towards the first lead block and tighten screw. (See also Chapter 6.3, "Furling line arrangement".)

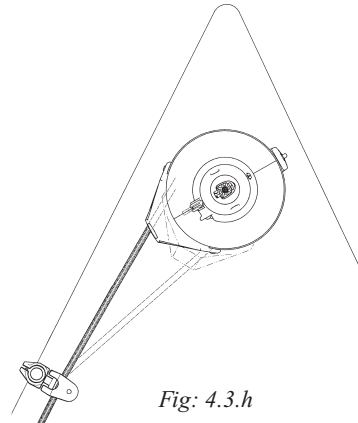


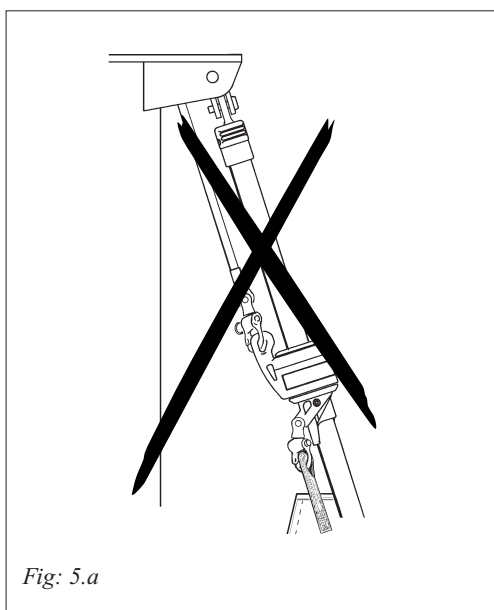
Fig: 4.3.h

5 Halyard routing

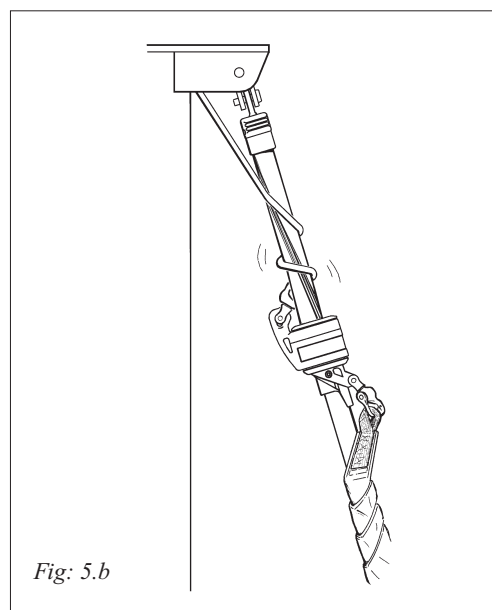
The angle between the halyard and the forestay must be 5–10° - see Fig: 5.4.c. If this angle is less, the halyard may wrap around the luff section when the sail is being furled, possibly damaging the halyard and the luff extrusion. Failure to observe what is happening in this situation may even result in damage to the forestay wire.



Incorrect halyard routing can promote "Halyard wrap" which may cause severe damage to the forestay, and put the entire rig at risk. If the sail is furled with the aid of a winch, take great care. It can be difficult to control the tension on the furling line.



May lead to

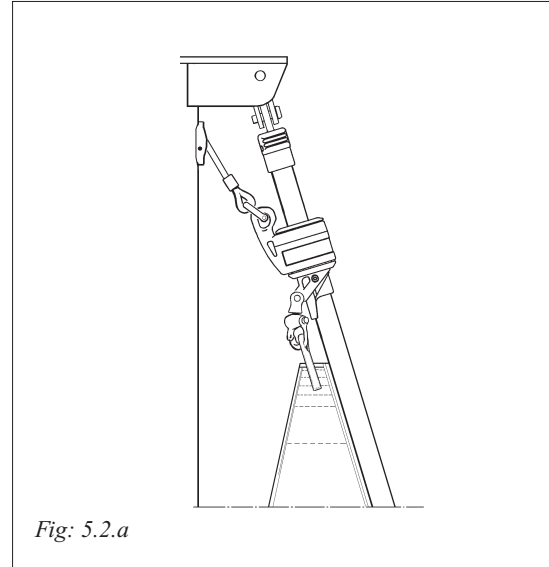


5.1 Halyard leads

To avoid halyard wrap, 2 halyard leads are included in the Furlex kit. These are easy to fit and are suitable for all makes of mast. When sailing, movement occurs between the wire halyard and the halyard lead. To prevent halyard wear, the halyard lead is made of bronze. This is "softer" than a wire halyard, so the halyard lead will wear before the wire. Halyard leads should be inspected once a year and any sharp edges smoothed with a file. The halyard lead should be replaced when wear reaches 50%. The halyard leads are not covered by the 5-year Furlex warranty.

5.2 Halyard sheave box

A sheave box can also be fitted to the mast to meet the 5–10° requirement. The sheave box will not damage the halyard, nor is it worn by the wire. Installation is more complicated but the box will eliminate the need to replace the halyard leads in future as above. Newly manufactured Seldén Masts on which Furlex is to be fitted are always fitted with a sheave box. Sheave box kits (with assembly instructions) are obtainable from all Furlex dealers.



5.2.1 Sheave boxes

WireHalyard	Ø 4 (5/32")	Ø 5 (3/16")	Ø 6 (1/4")
Rope Halyard	Ø 8(5/16")	Ø10(3/8")	Ø 12(1/2")
Sheave box	AL-45	AL-70	AL-90
Article no.	505-004-10	505-006-10	505-012-10
Sheave width	13 mm(1/2")	13 mm(1/2")	16 mm(5/8")

Fig: 5.2.b

5.3 Spinnaker halyard

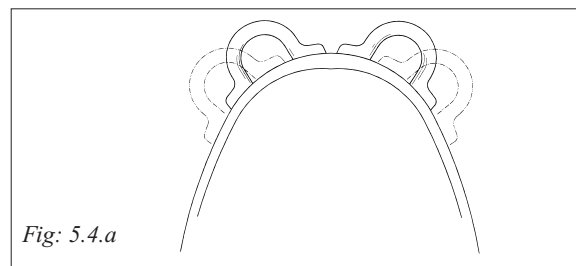
If the boat is equipped with a spinnaker halyard, this must be kept clear of the Furlex-system to avoid halyard wrap. An effective solution is to lead the halyard around the upper shroud and then down aft the spreaders.



Stowing a spinnaker halyard parallel to the Furlex stay is not recommended!

5.4 Fitting the halyard lead


The Furlex kit contains 2 halyard leads. If the mast is equipped with two genoa halyards they should each run through a halyard lead. The halyard leads can be fitted side by side or moved round the side of the mast if there is a lack of space.



To avoid corrosion between the bronze lead and the aluminium mast, each lead is supplied with a self-adhesive insulator sheet. It is important to fit this between the lead and the mast.

Figs. 5.4.c–5.4.e give the fitting measurements for Seldén masts. These measurements can also be used for other makes of mast, but the angle must be checked carefully.

An angle of more than 10° may result in unnecessary wear to the halyard lead.

 For the halyard routing to work properly, the halyard swivel must be in the correct position to achieve the required angle of 5–10°. If the sail does not have the required luff length, this needs to be adjusted. (See Sail, 7.1.)

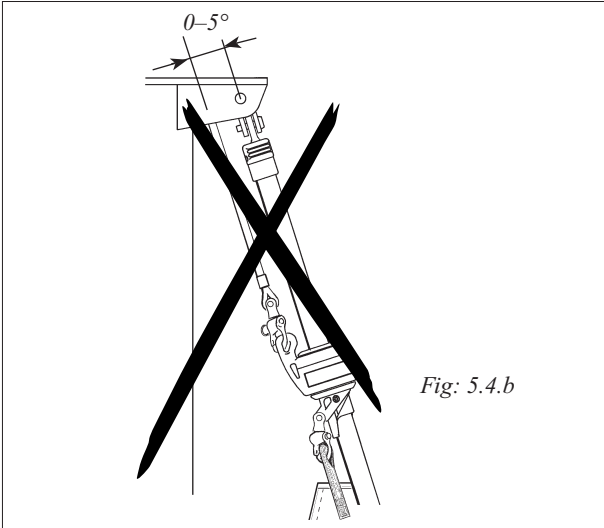


Fig: 5.4.b

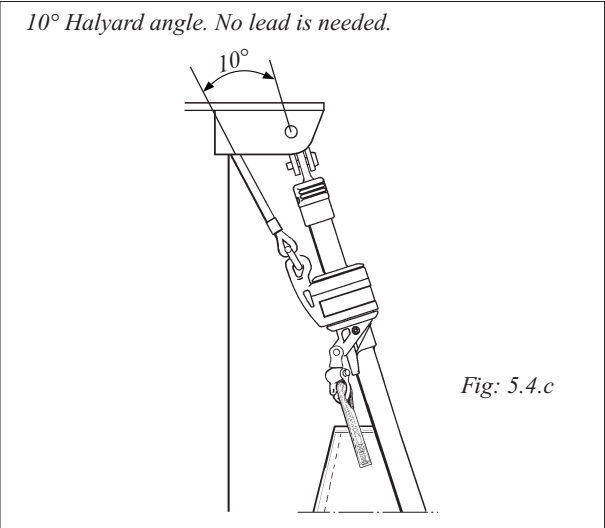


Fig: 5.4.c

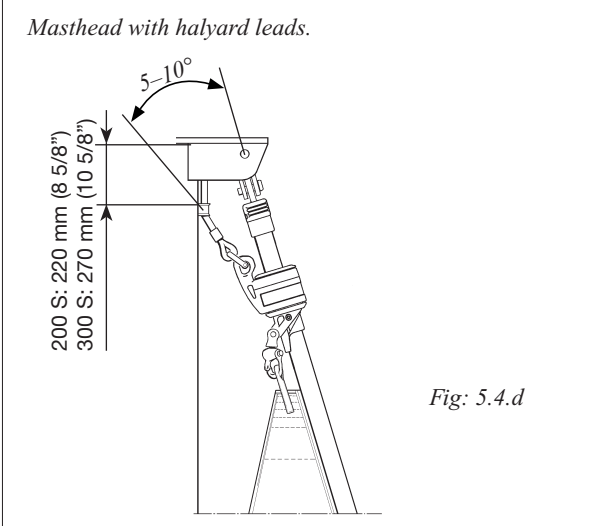


Fig: 5.4.d

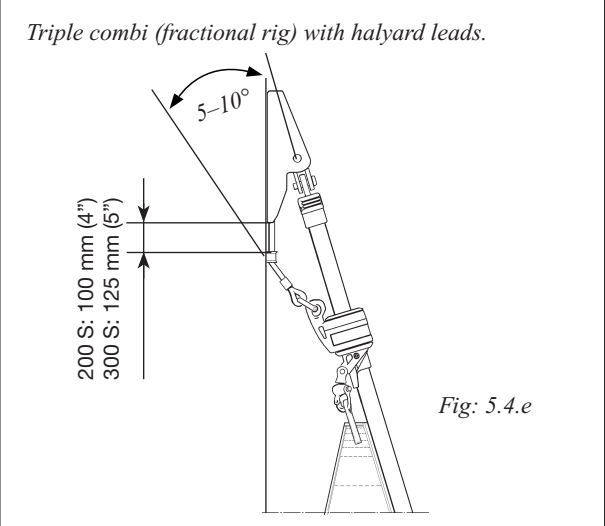


Fig: 5.4.e

Fitting instruction:

1. Measure the position of the leads. Mark the position with the self-adhesive insulator sheets.
2. Drill the holes with the enclosed Ø 5.3 mm (7/32”) drill bit, using the fitting as a jig. It is easiest to drill the holes before the Furlex stay is fitted.
3. Fit the halyard leads ”over” the respective halyard as the halyard shackles are too big to be fed through the eye.
4. Lubricate the screws with grease and mount the halyard leads. The screws are self-tapping M6 screws which can be screwed directly into the Ø 5.3 mm (7/32”) hole. The grease makes fitting easier and prevents corrosion.

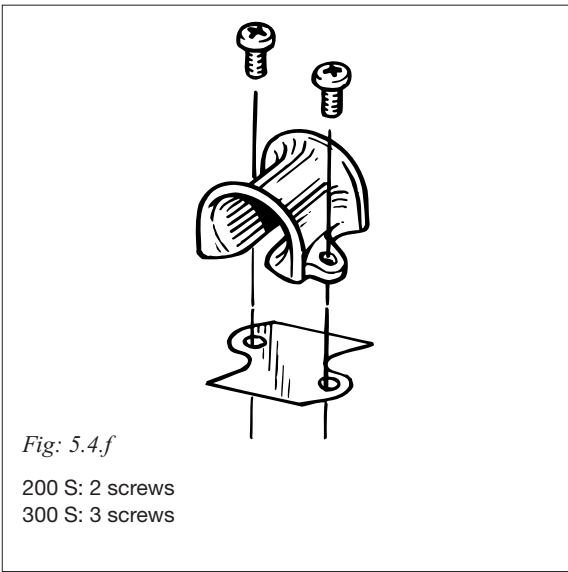


Fig: 5.4.f
200 S: 2 screws
300 S: 3 screws

6 Furling line arrangement

6.1 Functional description

As the sail unfurls, the furling line is wound onto the line drum. It is centred on the line drum through the hole in the line guide fitting, which has a stainless steel bush to reduce friction and wear on the line. The furling line is distributed evenly on the line drum by the light pressure exerted on it by the flexible line guard, which has low friction aluminium edge protectors.

6.2 Winding the line onto the drum

- Turning the luff extrusion by hand, wind approx. 30 turns of the furling line onto the line drum.

If the sail's ultraviolet (UV) protection is fitted on the *starboard side*, the furling line shall exit on the port side of the line drum. Turn the luff extrusion *clockwise*.

If the UV protection is fitted on the *port side*, turn the extrusion *counter-clockwise*. The line will then exit on the starboard side.-

- Secure the line in the tack snap shackle as per Fig: 6.2.a. Accidental unfurling is then prevented.

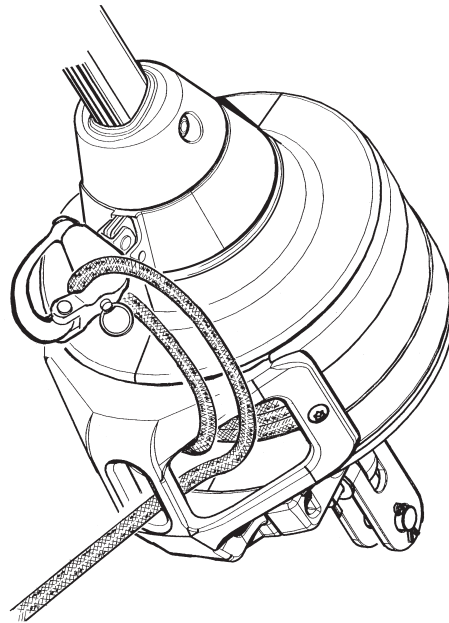
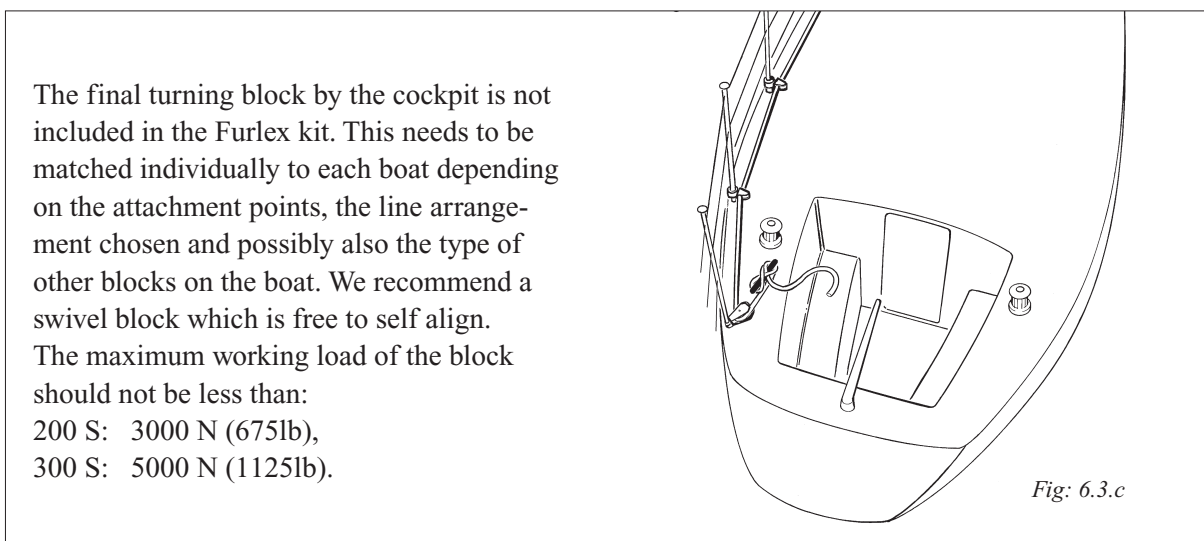
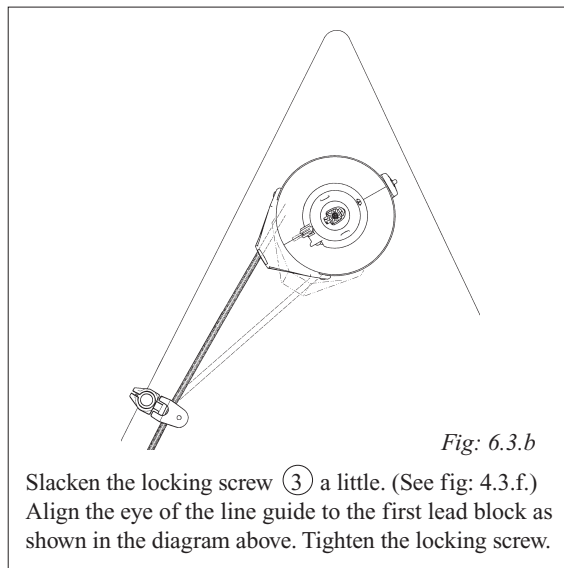
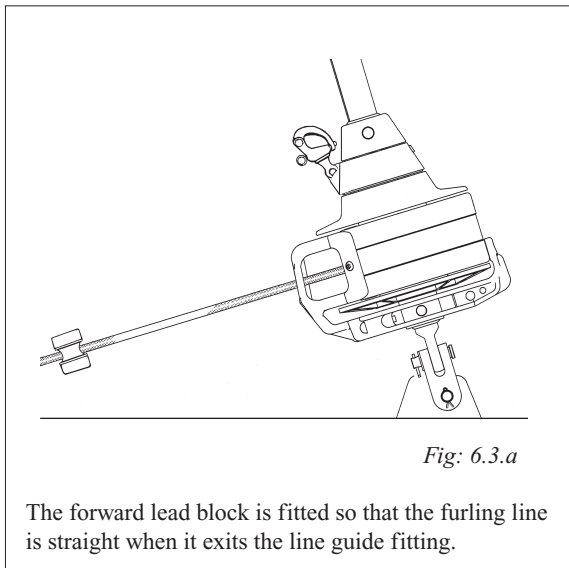


Fig: 6.2.a

To prevent from accidental unfurling the line can be secured into the snap shackle.

6.3 Routing of the furling line

The line should be led aft to the cockpit via the lead blocks included in the Furlex package. The lead blocks are mounted on stanchions and the pulpit. See Fig: 6.4.a–6.4.f for how to fit the 200 Series and Fig: 6.5.a for the 300 Series.



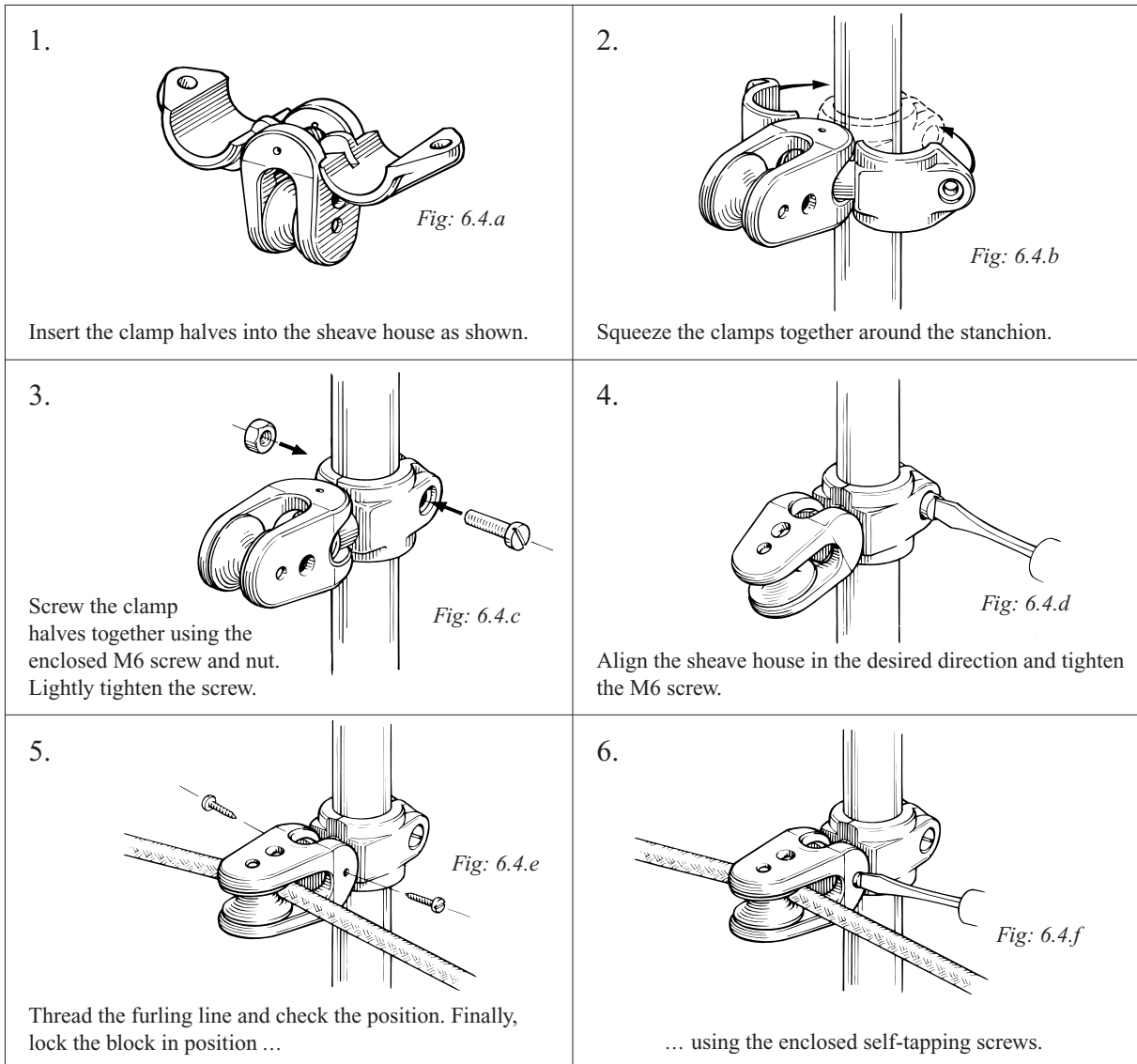
It must be possible to belay the furling line securely. A block with a Cam-cleat works well when securing a reef, but is unreliable if the boat is left unattended. The line should then be secured on a normal cleat for safety reasons. We recommend a single turning block in combination with a cleat.



If the furling line is accidentally released, the sail may unfurl and flap unchecked in strong winds. It could be damaged irreparably!

6.4 200 S: Fitting the stanchion blocks

The Furlex kit contains 4 stanchion blocks to be fitted to a 25 mm (1") stanchion or pulpit. The block has a ball-and-socket joint and can be angled in any direction.

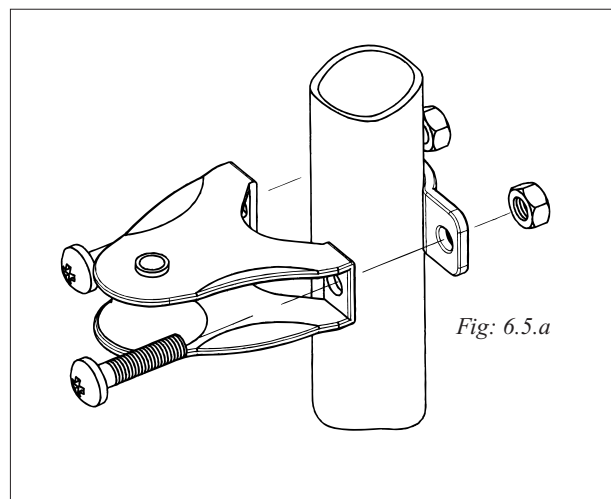


6.5 300 S: Fitting the stanchion blocks

The Furlex kit contains 1 articulated block to be fitted preferably on a Ø 25 mm (1") pulpit and 4 fixed stanchion blocks for fitting on a Ø 25-mm (1") stanchion. The fixed blocks can be fitted on a Ø 30 mm (1 1/4") stanchions, but the standard screws must be replaced by M6-25 mm screws.

Assembly:

The articulated block is fitted as shown in Figs: 6.4.a–6.4.f. The fixed blocks are fitted on the stanchion as shown in the diagram. The screw heads should be turned in towards the boat.



7 The Sail

7.1 Adapting the sail to the Furlex-system

- To fit the Furlex-system, an existing sail may need a number of modifications. The maximum luff length is calculated as shown in Table 7.1.1 and Fig: 7.1.b. FL -(F+E) (existing forestay length as per Table 3.5.1 – less head and tack deduction).



It is most important that the halyard swivel is located so that the halyard satisfies the 5–10° angle requirement. If the sail prevents the swivel from reaching the correct position, the luff length needs to be adjusted.

IF THE SAIL IS TOO LONG: Shorten the sail, e.g. in conjunction with changing to a luff tape compatible with Furlex.

IF THE SAIL IS TOO SHORT: Lengthen the sail by means of a wire pendant fitted to the head of the sail. Attach the pendant directly to the sail by a talurit splice to prevent unintentional removal, loss or exchange. All the boat's foresails should be adjusted to the correct luff length. See 7.3 below (There must be a minimum distance of 50 mm (2") between the top of the halyard swivel and the top guard when the sail is fully tensioned.

- "Cutback" for tack see Table 7.1.1.
- The luff tape must be compatible with the Furlex luff extrusion. See luff extrusion measurements in Table 7.1.1.
- If the sail is to be fitted with UV protection, this is best placed on the starboard side. The tack of the sail will then be in line with the luff grooves of the luff section when unrolled (see Chapter 12, "Reefing"). If the sail already has UV protection on the port side, the tack will be turned slightly to starboard. The free turn of the tack ring will function equally well.
- Use webbing loops at the sail head and tack instead of eyes (cringles). The sail will then form tightly round the luff extrusion when furling, and achieve a better shape when reefed.

7.1.1 Table of sail measurements

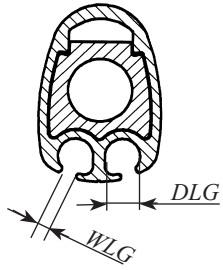
Furlex type	200 S	300 S	
Head deduction F	540 (21 1/2")	550 (22")	
Tack deduction E (Any additional toggle or link must be added to E)	330 (13")	400 (15 3/4")	
Cutback CB	60 (2 3/8")	80 (3 1/8")	
Internal diameter of luff groove DLG	Ø 6 (1/4")	Ø 7,5 (9/32")	
Width of luff groove WLG	3,0 (1/8")	3,0 (1/8")	
Overall extrusion dimensions	31x21(1 7/32"x13/16")	39x27(1 17/32"x1 1/16")	

Fig: 7.1.a

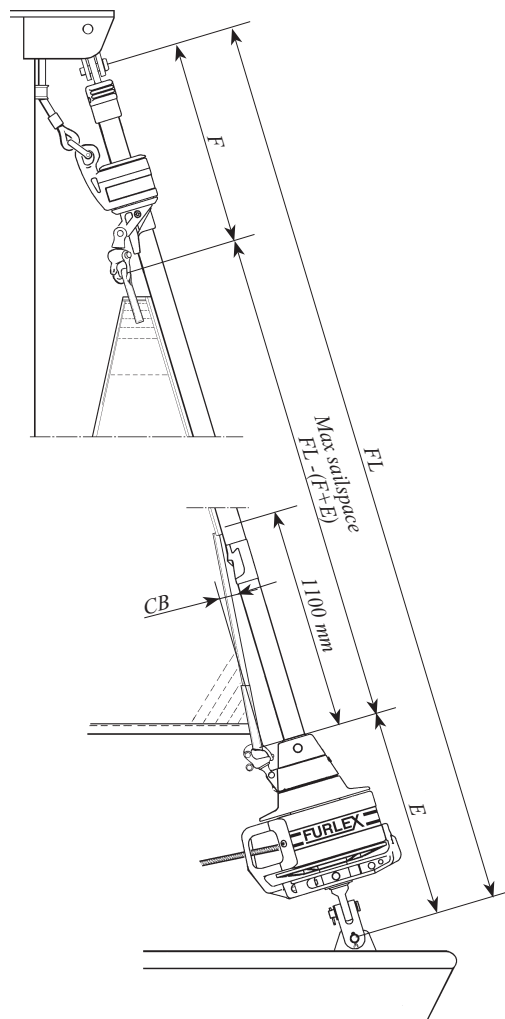


Fig: 7.1.b

7.2 Sail shape

The design of a sail can vary depending on its intended used and the desired performance.

The clew of the sail can be high or low.

In most cases a genoa has a low clew, with the foot sweeping as close to the deck as possible. To obtain the best sail trim when reefing, you must be prepared to adjust the sheeting position as required.

Smaller foresails such a cruising (working) jib will have a higher clew, giving better visibility under the sail, easier passage over the guard rail and less exposure to waves breaking over the foredeck in heavy weather. This type of sail often requires less adjustment of the sheeting position when reefed (See Chapter 12, "Reefing").

A furling genoa is usually a compromise between optimum performance and a more practical sail. The sail is designed for both light and strong winds, and is cut with less draft, giving it a flatter shape when reefed.

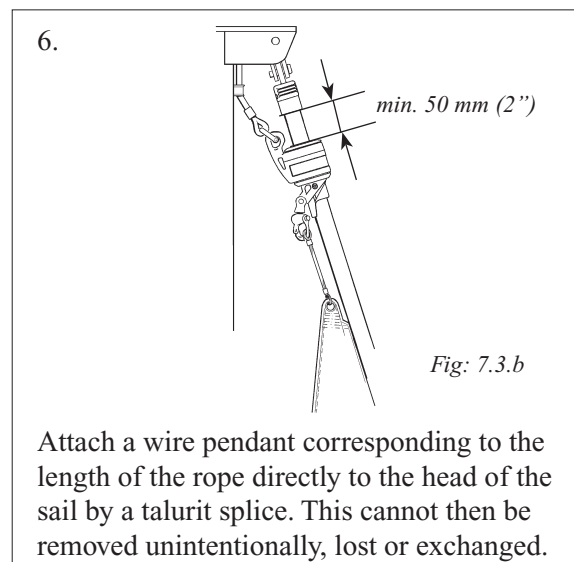
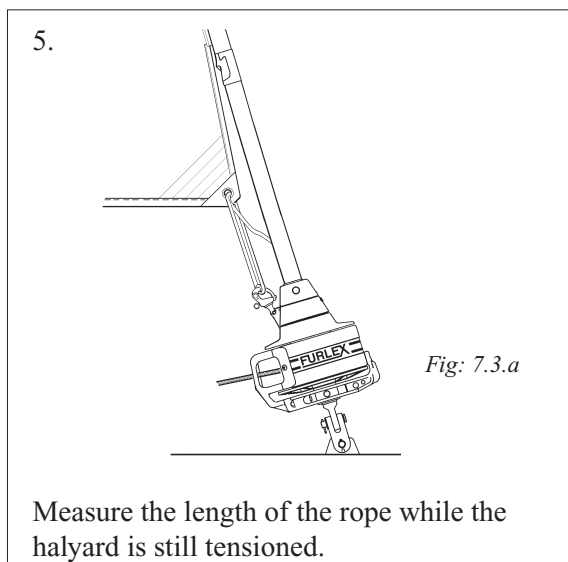
Several methods have been developed to improve the shape of a reefed sail. Many sailmakers use "foam" as a filling material along the luff of the sail. The foam is tailored to match the sail cut, and increases the diameter of the sail roll when reefing. A larger diameter of the sail roll gathers in more sailcloth per turn and the draft is reduced by varying amounts along the luff extrusion.

Together with the "free turn" (See Chapter 12, "Reefing") and the design of the Furlex luff extrusions, this can give the best reefed sail shape.

7.3 Determining the length of the pendant

To hoist the sail see the description in Chapter 11.1.

1. Attach the head of the sail directly to the halyard swivel.
2. Tack the sail at deck level with a piece of rope between the sail tack and the tack snap shackle on the lower bearing assembly.
3. Hoist the sail (See Chapter 11.1, "To hoist the sail"). Adjust the rope length at the tack so that the halyard swivel attains its top position, i.e. the 5–10° requirement is satisfied, when the halyard is fully tensioned.
4. There should never be less than 50 mm (2") clearance between the top of the halyard swivel and the top guard when the sail is fully tensioned.



7. All the boat's foresails must be adjusted to the correct luff length.



For the halyard routing to work properly, the halyard swivel must be in the correct position to achieve the required angle of 5–10°.

OPERATING MANUAL

To derive the maximum benefit and enjoyment from your Furlex-system, we recommend that you study this operating manual carefully.

All safety-related information is indicated by the following symbol.



Furlex is specified and manufactured using Metric dimensions.

To assist owners unfamiliar with this system, the approximate equivalent Imperial dimension are given in brackets.



This information must be followed to avoid damage to the system and the risk of personal injury.

The 5-year guarantee on the Furlex-system is only valid if the system is operated correctly according to the manual.

Unless you are fitting the Furlex-system yourself, you do not need to read the entire assembly manual. However, there are references in the operating manual to certain sections of the assembly manual. It is very important to read and note these cross references.

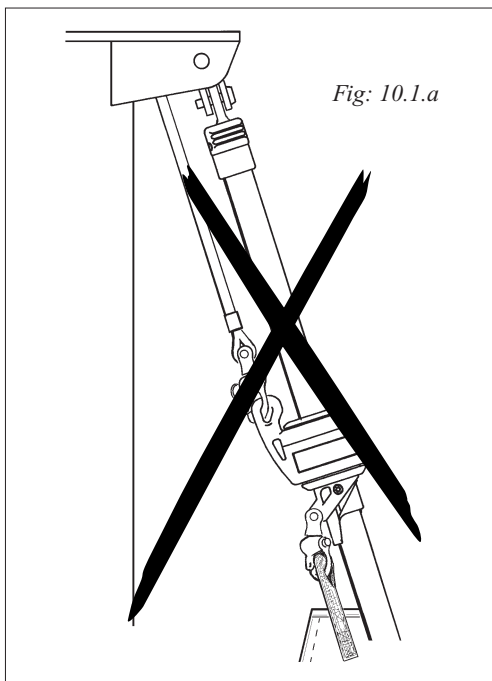
Any additional fittings recommended in the manual are obtainable from your nearest Furlex dealer.

10 Halyard Routing

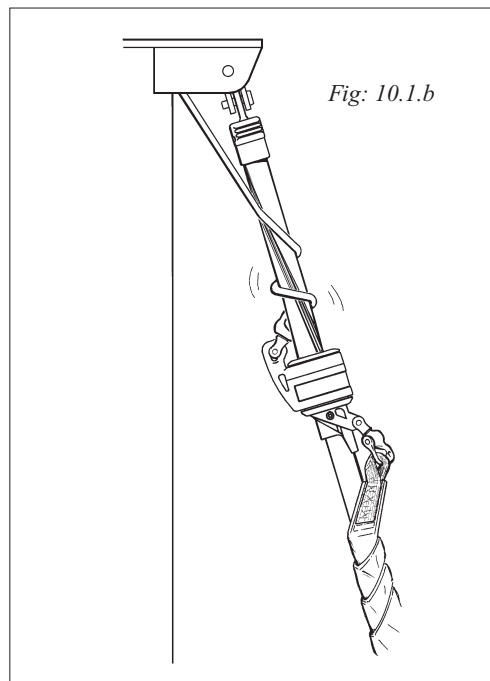
10.1 Summary

IMPORTANT POINTS!

- Routing the halyard is one of the most important aspects of system assembly for safe, trouble-free sailing using the jib furling and reefing system.
- The angle between the halyard and the forestay must be 5–10°. See Fig: 5.4.b. If the angle is less, the halyard may wrap around the luff section when the sail is being furled, possibly damaging the halyard and the luff extrusion. Failure to observe what is happening in this situation may even result in damage to the forestay wire.
- "Halyard wrap" may cause severe damage to the forestay and put the entire rig at risk. If the sail is furled with the aid of a winch, take great care. It can be difficult to control the tension in the furling line.
- If the 5–10° requirement is not satisfied, halyard leads or a sheave box must be fitted to avoid halyard wrap.
- 2 halyard leads are enclosed in the Furlex kit. Check if these are fitted.
- See also under "Halyard routing", Chapter 5.



May lead to



When sailing, movement occurs between the wire halyard and the halyard lead.

To prevent halyard wear, the halyard lead is made of bronze. This is a softer material than a wire halyard, so the halyard lead will wear before the wire.

Halyard leads should be inspected once a year and any sharp edges smoothed with a file. The halyard lead should be replaced when wear reaches 50%.

The halyard leads are not covered by the 5 year Furlex warranty.

10.2 Halyard sheave box

A sheave box can also be fitted to the mast to meet the 5–10° requirement. The sheave box will not damage the halyard, nor is it worn by the wire. Installation is more complicated but the box will eliminate the need to replace the halyard leads in future as above.

Newly manufactured Seldén masts on which Furlex is to be fitted are always fitted with a sheave box. Sheave box kits (with assembly instructions) are obtainable from all Furlex dealers.

See Table 5.2.1 and Fig: 5.2.a for further information

10.3 Spinnaker halyard

If the boat is equipped with a spinnaker halyard, this must be kept clear of the Furlex-system to avoid halyard wrap. An effective solution is to lead the halyard around the upper shroud and then aft of the spreaders.



Stowing a spinnaker halyard parallel to the Furlex stay is not recommended!

11 Sailing with Furlex

11.1 To hoist the sail



The forestay must be properly tensioned each time the sail is hoisted. You should therefore tension the backstay and any running backstays before hoisting the sail.

1. Tension the forestay for hard close-reach sailing **before** the sail is hoisted. If the sail should be hoisted and firmly tensioned before the forestay, this may put excess strain on the halyard, halyard swivel and sail when the forestay is tensioned afterwards.
2. Lay out the sail on deck. It should be carefully flaked down with the tack turned forward.
3. Turn the tack ring counter-clockwise if the furling line exits on the port side of the drum, or clockwise if it exits on the starboard side.
4. Attach the tack of the sail to the tack snap shackle.

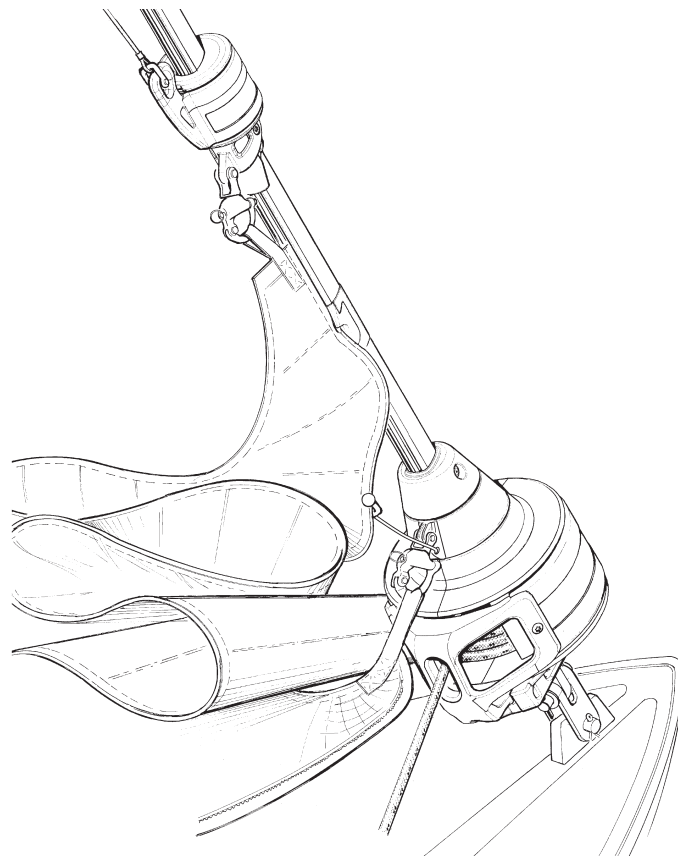
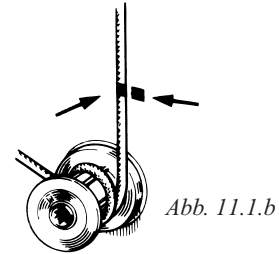


Fig: 11.1.a

5. Attach the sheet to the clew. Take the sheet through the lead block and then on to the cockpit. Put a figure-of-eight knot in the ends.
6. Tie the prefeeder rope to the hole under the tack shackle or through the tack shackle.
7. Attach the halyard to the upper eye of the halyard swivel.

8. Hoisting the sail in the correct groove through the sail feeder. If the furling line exits on the port side of the line drum, the sail should be hoisted in the starboard groove. If the line exits on the starboard side, use the port groove. Hoisting the sail in the "right" groove reduces initial resistance when furling the sail, which then has less of a "fold" along the forestay than if the other groove is used.
9. Hoist the sail. The pre-feeder assists luff tape feed by steering the sail in towards the luff extrusion and sail feeder at a small angle. Tension the halyard until a vertical crease appears in the luff of the sail, then slacken off until the crease disappears. Belay the halyard.
10. Note! After hoisting the sail, remove the prefeeder completely.
11. Furl the sail on the Furlex luff section by pulling on the furling line. Let the windward sheet run freely. Keep some tension in the leeward sheet, for example by placing a turn around a winch. It is important to furl the sail tightly and evenly, as a sail which is furled too loosely may blow out a little in strong winds. If the boat is left unattended, the sail may flap until it tears. A very loosely furled sail may also cause unnecessary wear, as the sail roll will swing back and forth in the wind.
12. Check the number of turns of the furling line remaining on the line drum. When the largest sail is furled tightly, there should be 3–5 turns left. To adjust the number of turns, detach the sheet and turn the Furlex luff extrusion by hand until the correct number of turns are on the drum. When furling in strong winds, the sail will roll more tightly, requiring more turns on the line drum and meaning that more line will be needed. Make sure you always have sufficient turns of line on the drum.
13. Check that the halyard swivel is at least 50 mm (2") from the top guard and that the **halyard angle satisfies the 5–10° requirement.**

14. Once all these points have been checked, mark the halyard as shown in the diagram to prevent over-tensioning by a winch or when the forestay/backstay is adjusted. Mark the maximum tension position of the backstay adjuster.



15. The forestay tension can now be adjusted without putting too much strain on the halyard.



Warning! Never tension the halyard when the sail is reefed or furled.

11.2 Unfurling the sail

(Partial unfurling: See Chapter 12, "Reefing")

1. Release the furling line and the windward genoa sheet. Allow these to run freely while the sail is being unfurled.
2. For a controlled unfurling manoeuvre, it is best to place a turn of the furling line around a winch or a half-turn around a cleat. This introduces some drag, which is particularly useful in stronger winds.

3. Place a turn of the leeward genoa sheet around a winch and unfurl the sail by pulling in the sheet. Once the wind catches the sail it will unfurl more easily. The best point of sail for unfurling is between close reach and beam reach, as the wind will then fill the sail quickly.
4. Place a few more turns of the sheet around the winch and sheet the sail in to the desired trim.

11.3 Furling the sail

1. Release the windward sheet and ensure that it can run freely.
2. Furl the sail by pulling the furling line. Release the leeward sheet but keep a little tension on it, for example by placing a turn around a winch. It is important to furl the sail tightly and evenly, as a sail which is furled too loosely can blow out a little in strong winds. If the boat is left unattended, the sail may flap until it tears. A very loosely furled sail may also cause unnecessary wear, as the sail roll will swing back and forth in the wind.
3. Belay the furling line carefully. If the boat is left unattended, the furling line should be belayed on a cleat for safety.



If the furling line is accidentally released, the sail may unfurl and flap unchecked in strong winds. If left for any length of time, it could be damaged irreparably!

If the boat is left for a fairly long period, it is a good idea to take down the sail and stow it below deck. It is then protected from UV radiation and dirt. Alternatively, a sail cover ("furling tube") can be used to protect the sail.

12 Reefing

The size of the working sail area is infinitely variable with a jib furling and reefing system. Even if the sail is designed as a furling sail incorporating foam etc. and the Furlex-system is equipped with a "free turn" (see below), a reefed sail can never achieve the same efficiency as an unreefed sail of equal size. If the boat is equipped with more than one furling sail, these can be changed to suit the different wind conditions.

12.1 Free turn

Furlex is equipped with a tack swivel, meaning that furling of the tack is delayed by one revolution in relation to the luff extrusion. This causes the sail to be flattened out a little before the tack and the foot are furled. Since the tack is reinforced by several layers of sail cloth, this will increase the sail roll more with each revolution than the rest of the luff, thereby impairing the shape of the reefed sail. Furlex compensates for this by means of the tack ring delay. **We refer to this function as the "Free turn"**.

The Furlex luff section has the **same diameter over its whole length**. The entire luff is furled in an even roll, right down to the tack of the sail. This is a requirement if the free turn is to be fully effective and give a satisfactory shape to the reefed sail.

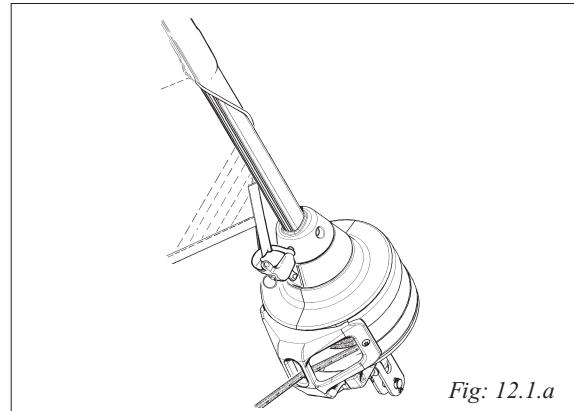


Fig: 12.1.a

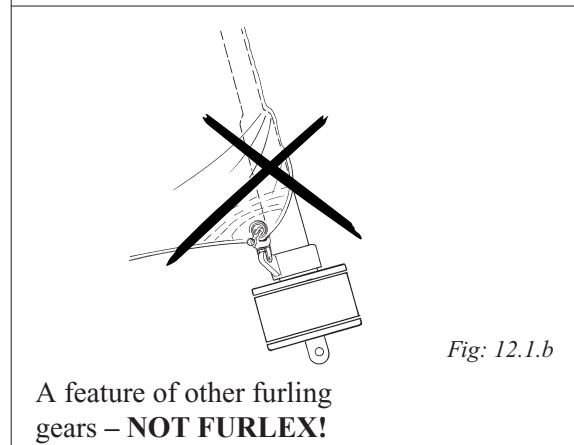


Fig: 12.1.b

12.2 Reefing under sail

- In strong winds it may be necessary to reef the sail. It is important then to furl the sail tightly, as this both preserves the sail and gives it a better shape.
- The best point of sail for reefing is on a close reach to beam reach. The wind will then partly fill the sail and help to improve its shape when reefed.
- If using a winch for the furling line, first check that there is no obstruction which may interrupt the furling operation and possibly cause damage.

1. Slacken off the leeward sheet until the sail just begins to flap along the luff.
2. Pull in the furling line so that the sail is furled and flattened out. Belay the furling line.
3. Repeat the procedure as required to obtain the desired sail area.



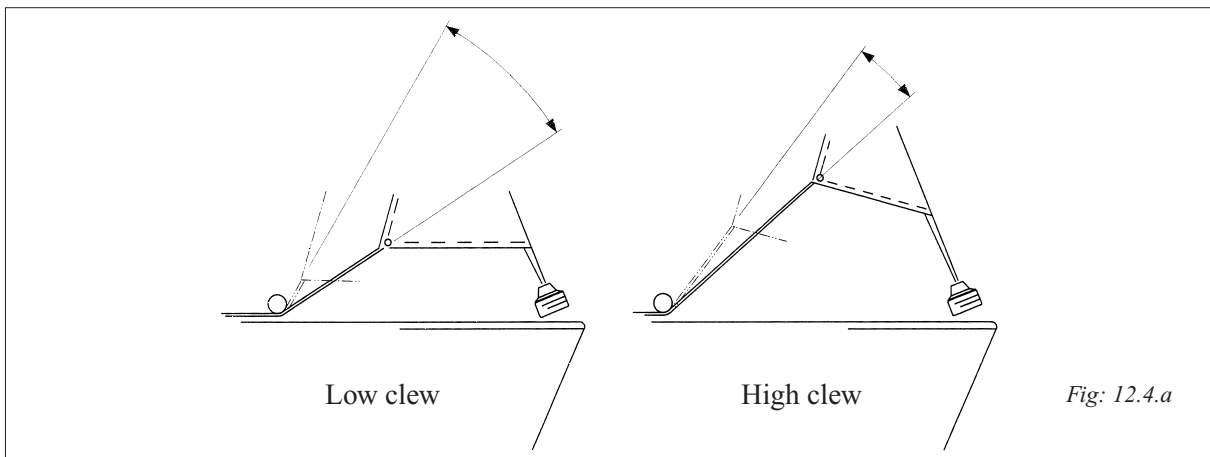
If using a winch for the furling line, first check that there is no obstruction which may interrupt the furling operation and possibly cause damage.

12.3 Setting a reefed sail from the furled position

- You will achieve the best sail shape by first unfurling the sail completely and then reefing down to the appropriate size. Pull in the furling line and keep the sheet well tensioned. The sail will then form a tight roll and its shape will be improved.
- If the wind is too strong, or there are other reasons for not wanting to unfurl the sail completely, it can be reefed from the furled position. The sail should then be furled relatively tightly. The sail cannot be expected to have as good a shape when using this method. Wear on the sail is also increased.

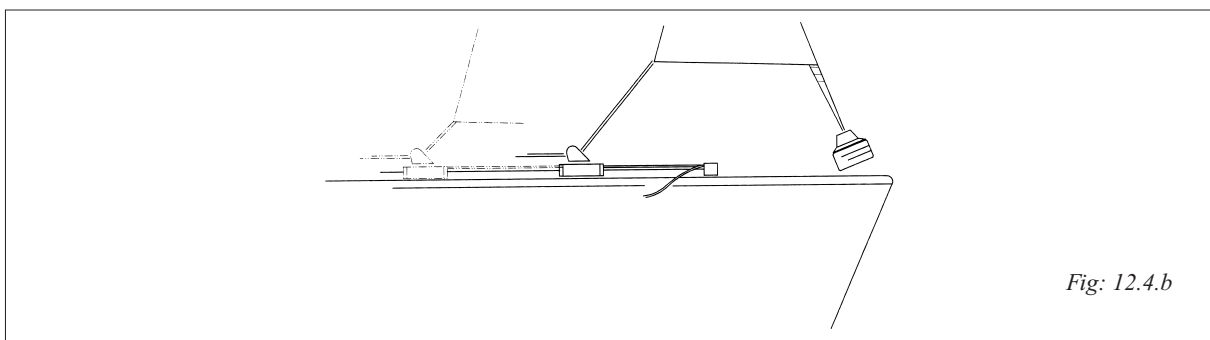
12.4 Adjusting the sheeting position

When the sail is reefed, it may be necessary to adjust the sheeting position. For a sail with a low clew, the sheeting position has to be adjusted even when the sail is slightly reefed, a sail with a high clew requires less adjustment. See Fig: 12.4.a. As a rule, however, **you must be prepared to adjust the sheeting position as necessary to give the best sail trim.**



The angular variation of the sheet relative to the deck is less for a high-clew sail. The comparison is based on the same number of furling revolutions.

Adjustment of the sheeting position is made considerably easier if a floating sheet point arrangement is used. The traveller position is adjusted along the track by means of a line running through a block in the front of the track. The line is best routed to the cockpit where it is secured. The traveller position can also be adjusted under load with the aid of a winch.

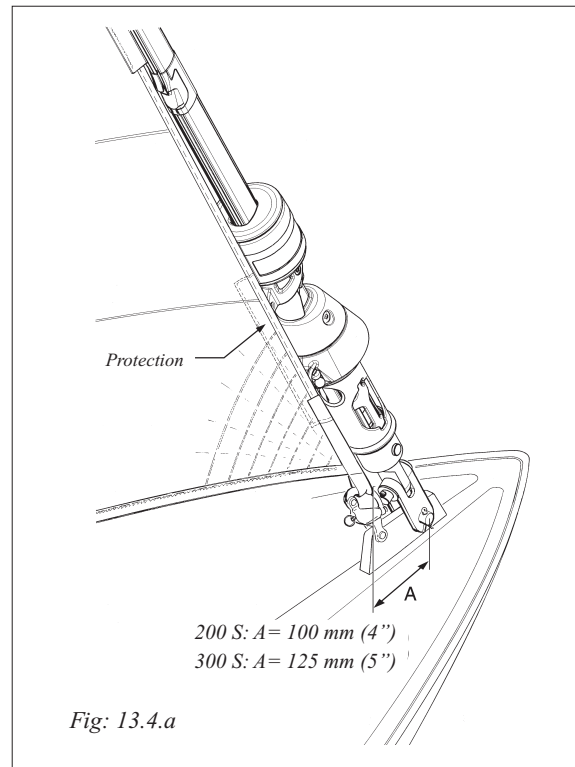


Many furling foresails have markings in the foot for different reefing positions. After you have tested combinations of sail area and sheeting position to see which function satisfactorily, you can use these markings as a reference and mark suitable sheet points on the track.

13 Furlex for racing

- Many racing yachtsmen have exploited the advantages of the jib furling and reefing system with great success. The sail can be partly furled before the start, giving good visibility and easy manoeuvring of the boat. Just before starting, the sail is unfurled and the boat crosses the line under full sail. If the boat has a small crew, the advantages are obvious.
- The Furlex can be easily and quickly reconfigured from a furling jib system to a twin-groove racing headfoil. The line guide and line drum are dismantled without removing the forestay from the boat and the halyard swivel lowered below the sail feeder.
- When racing with a large crew, the sail can then be tacked at deck level, enabling the full hoisting length of the headfoil to be utilized. The twin luff grooves offer the option of quick sail changes.
- To avoid chafe between the sail and lower bearing assembly, the minimum distance between the forestay attachment and the forward edge of the tack must be A as shown in Fig 13.4a.
- For added protection, or if the A dimension cannot be achieved, fit extra reinforcement to the sail where chafing may occur.

Furlex is converted for racing by dismantling the line guide and line drum in the manner described under **"Dismantling"** in Chapter 17.3–17.4. The sail feeder is also removed (Chapter 17.2) and the halyard swivel moved down to the lower bearing assembly. Re-fit the sail feeder and your Furlex is ready for racing!



14 Adjusting the forestay length

The Furlex 200 S and 300 S may be supplied with or without an integral rigging screw.

14.1 Furlex with rigging screw

On a system with an integral rigging screw, the forestay length can be adjusted. This is the primary task of the rigging screw. Tensioning the forestay is best done with the backstay, which has a more favourable angle.

The forestay length is adjusted as follows:

Tool: 1 Torx spanner or screwdriver.
(The Torx spanner set enclosed with the Furlex-system is suitable)
1 pair of long-nosed pliers
2 wrenches

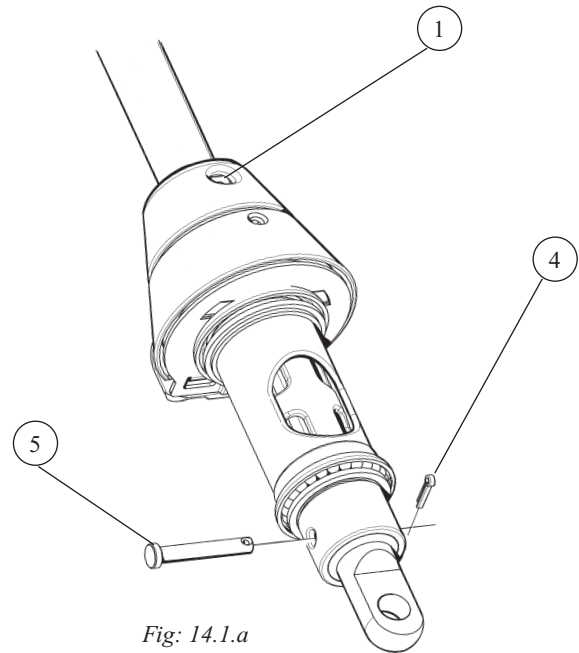


Fig: 14.1.a

1. Unfurl the sail, slacken the halyard or remove the sail.
2. Loosen the screws ① (x 2) in the adapter which fastens the luff extrusion to the lower bearing assembly.
3. Remove the split pin ④ and clevis pin ⑤ which hold the lower bearing assembly in the terminal assembly.



NOTE! Do not remove the lowest clevis pins which connect the forestay to the boat!

4. Lift the lower bearing assembly up the luff extrusion to expose the rigging screw. Slide it carefully so that the stainless steel inner tube does not scratch the extrusion. Use cloth or paper for protection.
5. Secure it in this position, for example using a spare halyard connected to the tack snap shackle.

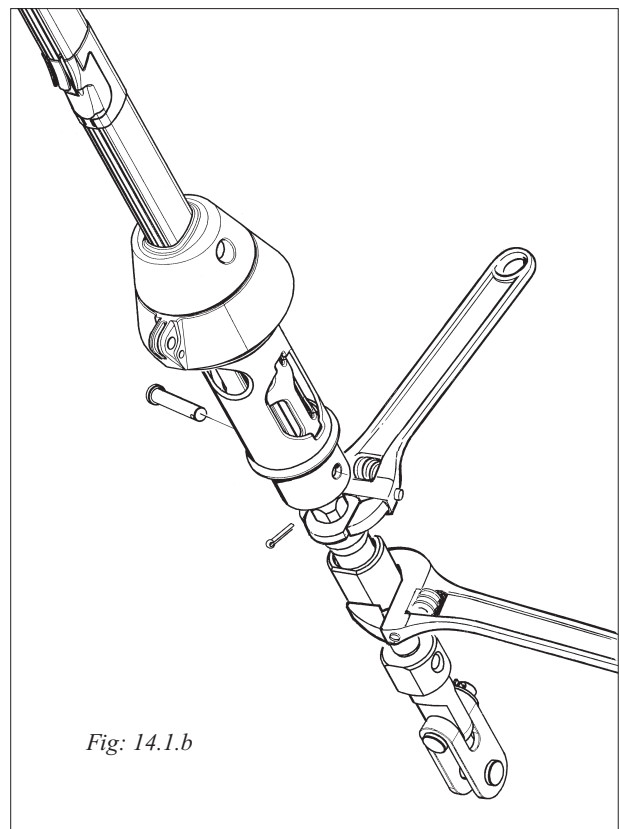


Fig: 14.1.b

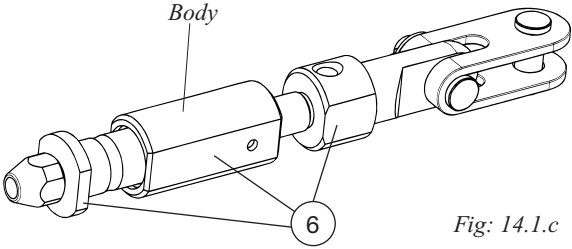
6. Place one wrench over the flat faces of the wire terminal and the other over the flat faces of the rigging screw body. Adjust the position of the rigging screw by turning the **body of the rigging screw** until the desired forestay length is obtained. **Note! Do not turn the wire terminal.**



The rigging screw has a stop at the maximum position to which it can be unscrewed. Do not overload this stop by trying to unscrew the rigging screw further with the tool. The values given in the table below for adjustment must not be exceeded!

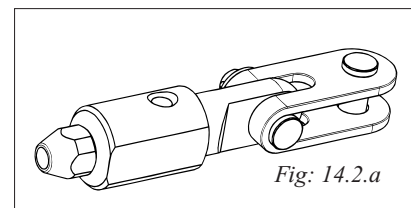
7. Re-adjust so that the flat faces ⑥ (Fig:14.2.a) of the wire terminal and rigging screw body are aligned.
8. Re-fit the lower bearing assembly. As the inside of this matches the flat faces, it will lock the rigging screw when fitted.
9. Tighten the screws ① firmly. If the travel of the rigging screw is not sufficient, see below under "Furlex without rigging screw".

14.1.1 Rigging screw adjustment

 <p>Fig: 14.1.c</p>		Forestay dimension	Adjustment	Part.no
	200 S	Ø6 (1/4")	60 (2 3/8")	174-536-11
		Ø7 (9/32")	60 (2 3/8")	174-537-11
		Ø8 (5/16")	60 (2 3/8")	174-538-11
	300 S	Ø8 (5/16")	80 (3 1/8")	174-519-11
		Ø10 (3/8")	80 (3 1/8")	174-520-11

14.2 Furlex without rigging screw

If the Furlex-system is not fitted with a rigging screw, the forestay can be lengthened by fitting extra toggles, see Table 3.3.3. Several toggles are usually required to change the mast rake noticeably. These can be fitted at the upper or lower end of the system. On a Furlex with an Ø 8 mm (5/16") forestay of the normal length (15400 mm) (50'6"), the masthead is moved 158 mm (6 5/8") aft if the forestay is lengthened using a standard toggle H=50 mm (2").



To shorten the Furlex-system, the forestay wire and the luff extrusion must be shortened. See "Dismantling", Chapter 17 and "Assembly of the Furlex-system", Chapter 4.



NOTE! Never shorten the system by removing the lower Furlex toggle. (See "Deck attachments", Chapter 3.3)

A Furlex-system can be retrofitted with a rigging screw. Contact your Furlex dealer.

15 Maintenance of the Furlex-system

To ensure that the system rotates easily and functions satisfactorily year after year, regular maintenance should be carried out. This should be done once a year, or perhaps when the boat is unrigged at the end of each season. Maintenance is simple, even when the Furlex is rigged on the boat.

Halyard leads should be inspected once a year and any sharp edges smoothed with a file.

The halyard lead should be replaced when wear reaches 50%

15.1 Lubricating the lower bearing assembly

Lubricate all ball bearings as described below using the grease enclosed with the Furlex kit. Lubricating holes **A**, **B** and **C** are for the most important bearings to be greased, as the Furlex-system rotates around these. However, lubricating hole **D** is rather more difficult to reach. This is for the tack ring's lower bearing, which only rotates one revolution on each furling operation. This does not need to be lubricated as frequently; once every other lubricating cycle should be sufficient.

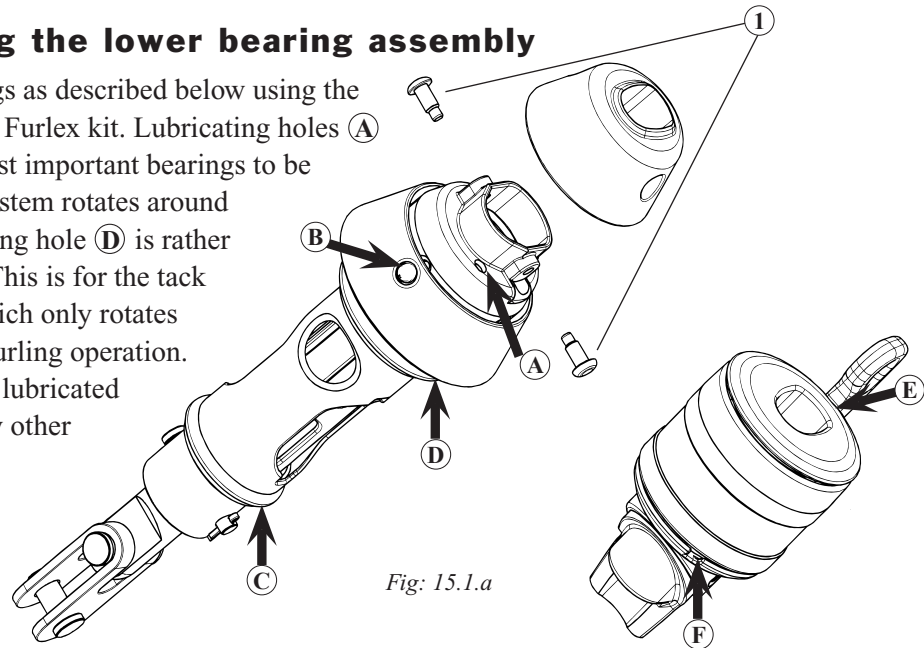


Fig: 15.1.a

Tools: 1 Torx spanner or screwdriver. (The Torx spanner set supplied with the Furlex-system is suitable.)
1 pair of long-nosed pliers

For best results, first rinse the system with fresh water and allow it to dry.

A

1. Loosen the screws **1** (x 2) fastening the adapter to the lower bearing assembly. Slide the adapter up the luff extrusion.
2. Press grease into the hole marked **A** . Re-fit the adapter and tighten the screws **1** firmly.

B

1. Press grease into the hole **B** on the front of the tack ring.

C

1. Press grease into the slot **C** between the terminal part and the line drum.

D

1. Dismantle the line guide and line drum halves. See "Dismantling", Chapter 17.3–17.4.
2. Press grease into the slots in the bearing **D** which is now exposed.
3. Re-fit the components in reverse order.

15.2 Lubricating the halyard swivel

1. Bring the halyard swivel down to the sail feeder.
2. Press grease into the upper bearing through the recess **E** and into the lower bearing through opening **F** in the plastic cover.

15.3 Cleaning the Furlex

Wash and rinse the entire Furlex-system with fresh water and a mild detergent to remove dirt and salt crystals.

Note! Some detergents contain substances which can cause aluminium to corrode, so it is important to rinse all detergent off thoroughly.

When the parts have dried, the anodized surfaces of the luff extrusions can be treated with a silicon-free boat polish or wax. This offers good protection and prevents particles of dirt from adhering and then soiling the sail. The stainless steel components can be treated with a suitable polish.

15.4 Storage

The Furlex-system is preferably stored with the mast during the winter.



Under no circumstances should an unwashed or damp Furlex be wrapped in plastic or other impervious material.

In areas where frost can occur, the Furlex should be stored in a dry place or with its centre sections raised. This is to avoid ice damage to luff sections at sub-zero temperatures.

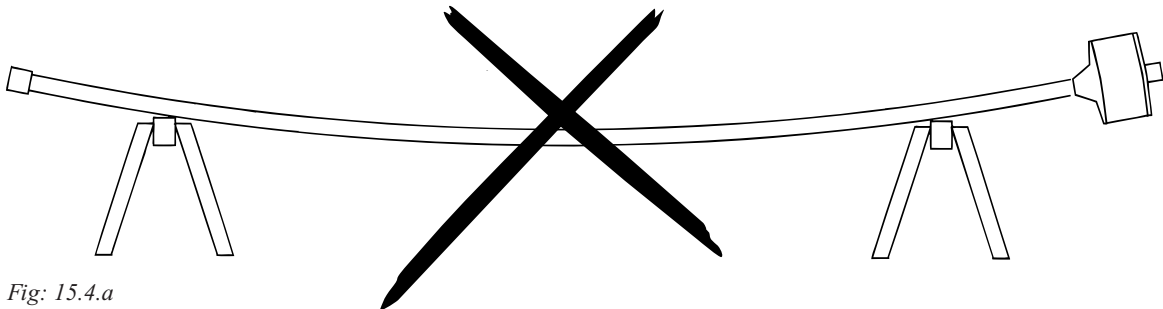


Fig: 15.4.a

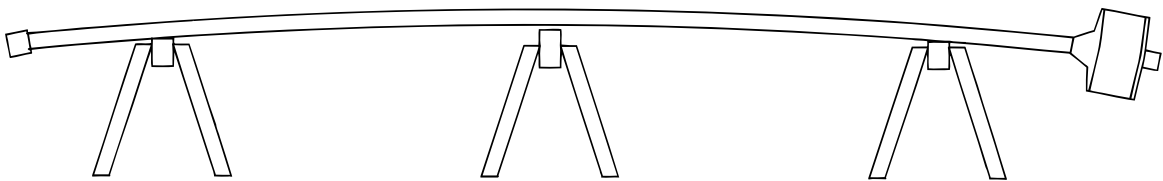


Fig: 15.4.b

16 Rigging

The Furlex-system is best transported and rigged together with the mast.

16.1 Fitting the Furlex on a stepped mast

1. Slacken the **backstay** as much as possible, but make sure that any rigging screw is not unscrewed so far that the threads are no longer visible "on the inside".
2. Pull the masthead forward using the genoa halyard. Secure the halyard using a "D" shackle or tie



Always use a strong "D" shackle or tie the halyard.

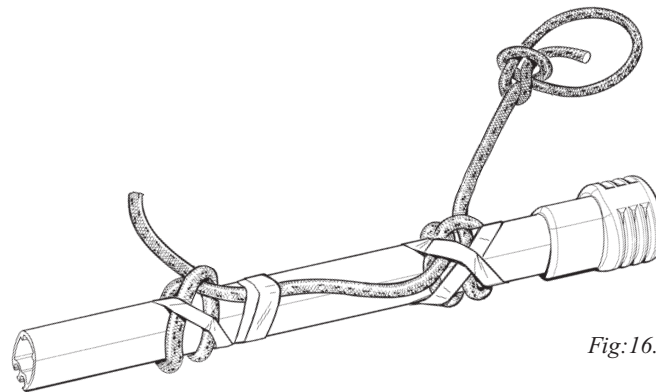


Fig:16.1.a

3. Tie a strong, flexible line around the luff extrusion. Make two clove hitches, the upper approx. 1 m (39 3/8") from the top, taping over the knots so that they cannot slide.
4. Hoist the stay using a spare halyard.
5. "Go aloft" and attach the top end of the Furlex-system to the forestay attachment. Always use a proper bosun's chair. If there are no free headsail halyards use the main halyard. For further information, see Seldén Mast AB's "Hints and Advice" on "Working aloft" or contact your Furlex dealer.

6. Attach the stay to the headbox, then to the deck fitting. The split pin for the clevis pin should be opened by $\sim 20^\circ$. It will then retain its shape on dismantling, enabling it to be used again.

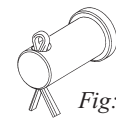


Fig:16.1.b

7. **Rigging screw:** Adjust the forestay to the desired length. (See chapter 14.1).
8. Tension the forestay to 20% of the wire's breaking load. As the tension on the forestay cannot be measured easily when it is encased in the luff extrusion, this can be done using the backstay. Owing to the difference in the angle of these stays relative to the mast, this is on a Masthead rig equivalent to approx. 15% of the backstay's breaking load, assuming that it is the same diameter as the forestay. (Forestay tension = approx. 1.25 x backstay tension.)

A firmly tensioned stay offers the least furling resistance.

For further information, see Seldén Mast AB's "Hints and Advice" or contact your Furlex dealer.

16.2 Stepping the mast with Furlex fitted

1. Lay the mast with the front uppermost.
2. Connect the top end of the Furlex-system to the forestay attachment.
3. Lift the mast with the Furlex-system lying on the leading edge of the mast.
4. Have one person watching the Furlex-system to ensure that it does not get caught when lifting the mast. Keep the end of the stay outside the deck area in order to avoid damage.
5. Attach the stay to the boat as described in Chapter 16.1 section 6–8.

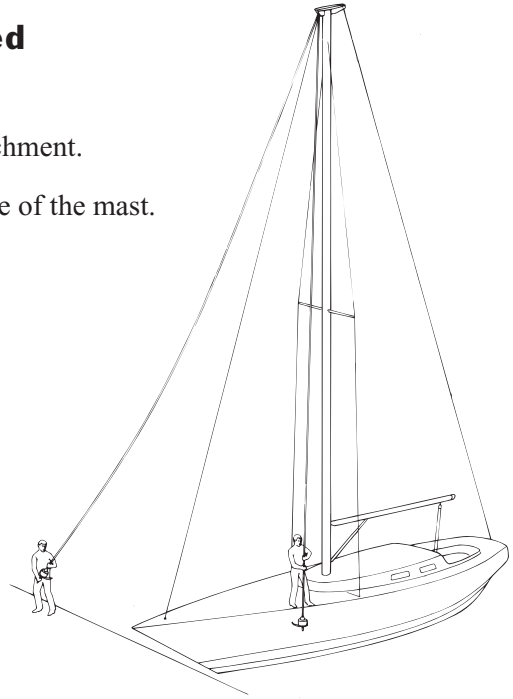


Fig: 16.2.a

17 Dismantling



NOTE! Do not dismantle the halyard swivel or lower bearing assembly. You will find it difficult to re-assemble them correctly (the ball-bearings are loose and difficult to refit!). Contact your Furlex dealer if service is required.

17.1 Halyard swivel

The halyard swivel can be removed from the system by removing the top guard and sliding it over the end of the forestay wire. The stay also has to be detached from the mast.

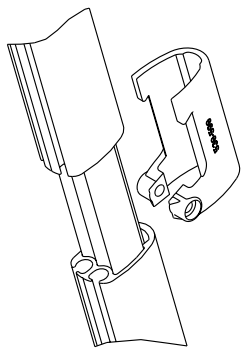
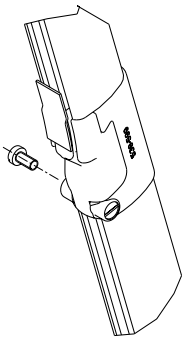
Alternatively, it can also be pulled downwards in conjunction with dismantling the sail feeder and removing the lower bearing assembly.

17.2 Sail feeder

Removing the sail feeder:

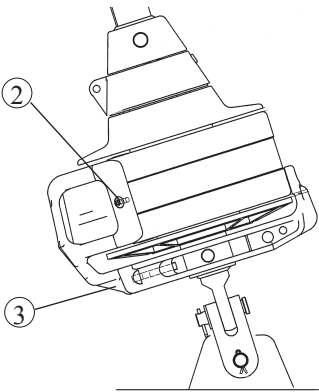
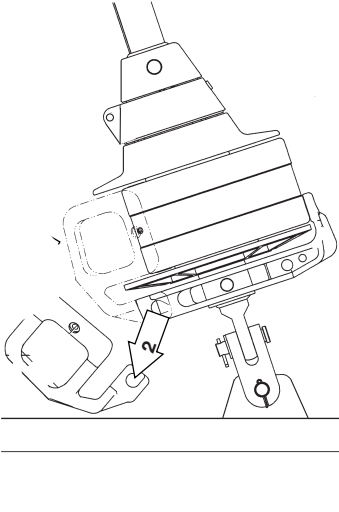
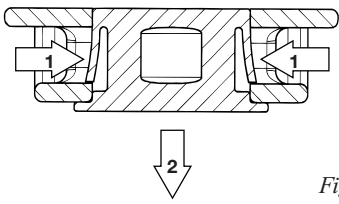
<p>1.</p> <p>17.2 a</p> <p>Secure the stainless steel sail feeder with adhesive tape to prevent it from falling overboard during disassembly.</p>	<p>2.</p> <p>Fig: 17.2.b</p> <p>Remove the screws.</p>	<p>3.</p> <p>Fig: 17.2.c</p> <p>Remove the sail feeder and twist off the connector.</p>
---	--	---

Re-installing the sail feeder:

<p>4.</p>  <p style="text-align: right;"><i>Fig: 17.2.d</i></p> <p>Push on the connector from the front of the luff section.</p>	<p>5.</p>  <p style="text-align: right;"><i>Fig: 17.2.e</i></p> <p>Hook on the sailfeeder at its upper edge. Secure with tape. Fit the screws.</p>
---	--

17.3 Lineguide

1. Unwind all the line from the line drum. Note the number of turns of line (for reassembly).

<p>2.</p>  <p style="text-align: right;"><i>Fig: 17.3.a</i></p> <p>Loosen screws ② and slacken screw ③ off a few turns.</p>	<p>3.</p>  <p style="text-align: right;"><i>Fig: 17.3.b</i></p> <p>Lower the line guide fitting and remove it.</p>
<p>4.</p>  <p style="text-align: right;"><i>Fig: 17.3.c</i></p> <p>Press the spring clips in (Arrow 1) and remove the locking block downwards.</p>	

5. Remove the line drum housing from the line drum.

17.4 Line drum

1. Dismantle the line drum halves. One turn of the furling line wound around the line drum during disassembly prevents the free half of the drum from falling overboard.

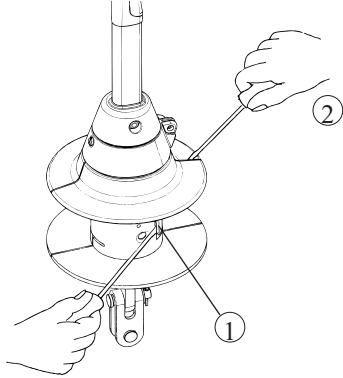


Fig: 17.4.a

Insert a screwdriver ① under one of the connecting clips. At the same time, press another screwdriver ② between the drum halves on the same side so that these are forced apart 3–4 mm.

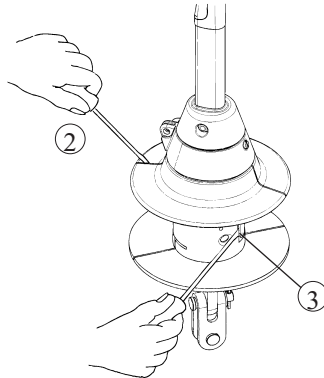


Fig: 17.4.b

Keep screwdriver ② in the same place and turn the drum half a revolution. Release the second clip ③ in the same way.

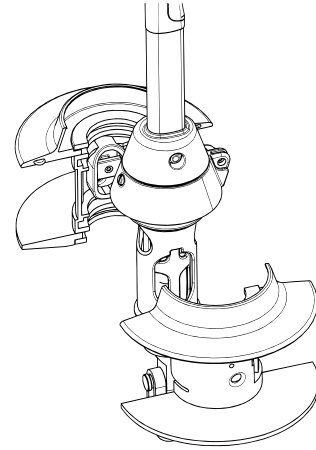
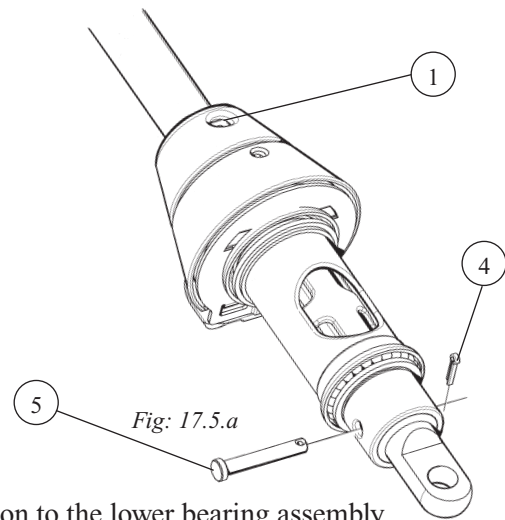


Fig: 17.4.c

The line drum halves now separate.

17.5 Lower bearing assembly

Tools: 1 Torx spanner or screwdriver (The Torxspanner set included with the Furlex-system is suitable)
1 pair of long-nosed pliers
2 wrenches



1. Undo the screws ① (x 2) which fasten the luff extrusion to the lower bearing assembly.
2. Undo the split pin ④ and clevis pin ⑤ which hold the lower bearing assembly in the terminal assembly.

3. Lift the lower bearing assembly up the luff section so that the terminal assembly is exposed. Slide it carefully so that the stainless steel inner tube does not scratch the luff section. Use cloth or paper for protection.

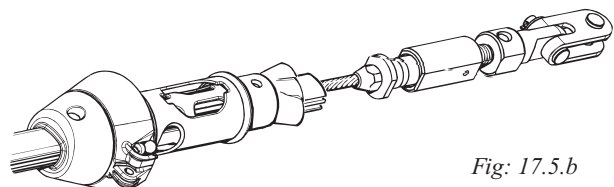
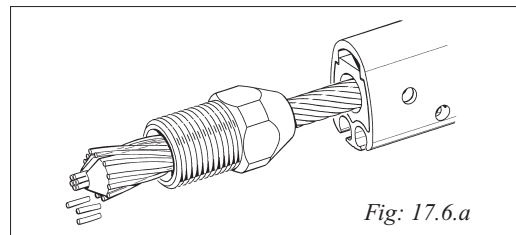


Fig: 17.5.b

4. Remove the terminal (or rigging screw) assembly from the socket. The thread is held by a locking adhesive. If it cannot be turned, heat the terminal/rigging screw to approx. 100°C (212°F) and unscrew the terminal/rigging screw while hot.
5. The lower bearing assembly can now be removed.

17.6 Wire terminal

1. Remove the spacer bush. This has a longitudinal slot to allow the wire to be removed. (Only applies to Furlex without rigging screw.)
2. Remove the terminal part (or rigging screw) from the socket. See fig. 17.5.b & Fig: 4.2.a.
3. Remove the former from the bottom of the eye part.
4. Replace the terminal, then loosen it ~2 turns.
5. Tap the eye of the terminal part (or rigging screw) so that the socket is pushed up the wire. If-necessary, tension the wire in a vice. There should be at least 10 mm of free wire between the top of the socket and the jaws of the vice. Be careful to protect the wire against damage by the vice jaws.
6. Unscrew the terminal part again.
7. Cut all wire strands protruding outside the wedge at the bend by approx. 5 mm (3/16"). See Fig: 17.6.a.
8. Prise the wedge apart slightly by inserting a small screwdriver into the slot and turning. Tap on the screwdriver so that the wedge slides off the wire.
9. Twist the wire strands into the correct positions around the core (counter-clockwise when seen from underneath) and remove the socket.
10. The wire can now be pulled out of the luff extrusion.



NOTE! If the luff extrusions are to be disassembled prior to a replacement of a luff extrusion etc. – do not pull out the wire. Go to Chapter 17.7.

Prior to reassembly of the forestay:

Check that the shape of the wedge was not damaged on dismantling. If so, replace it.

Cut the wire core flush with the outer strands. Remove any burrs with a file.

The decrease in forestay length which results has very little effect on the mast rake. A decrease of 5 mm (3/16") in forestay length causes the masthead to move forward 16 mm (5/8") on a 15 400 mm (50'6") forestay.

The decrease in length can also be compensated for by an increase in stay tension of 5% of the wire's breaking load compared with before. (However, permanent tension must not exceed 20% of the breaking load of the wire.) If this reduction in wire length is unacceptable, the total decrease can be made equal to a toggle length. The reduced measurement is compensated for by fitting an eye/fork toggle (see Table 3.3.3).

The luff extrusion and possibly the sail also should be shortened accordingly.

17.7 Luff extrusion system

For a better understanding of the following instructions, we recommend that you first read the section on assembly on Chapter 4.1.

1. Make sure that the luff extrusions are straight and placed on a flat surface.
2. Slide the wedge over the core of the wire again.
3. Push out the locking pin at the lower end of the 1000 mm (39 3/8") luff extrusion.
4. Hold the luff extrusion firmly and pull the wire's eye terminal. This will bring the forestay, joint sleeves and distance tubes out together, enabling the extrusions to be separated.

If, due to contamination or damage this method fails the connection parts protruding boss' can be drilled out. Use a Ø 6 mm drill bit for 200 S, Ø 8 mm for 300 S.

Reassembly of the luff extrusion.

1. Check all metal corners, edges and holes for damage, and file down if necessary.
2. Clean the wire and all extrusion parts with fresh water.
3. Insert the wire with distance tubes and joint sleeves from the top.
4. As the forestay progresses down, reassemble the connection parts at each join in turn.
5. Push the locking pin in the 1000 mm extrusion back. Use locking adhesive.

18 Trouble shooting

	Problem	Probable cause	Action
18.1	"The sail will not unfurl or will only partly unfurl."	<ul style="list-style-type: none"> • The jib halyard is wrapped around the luff extrusion. • Another halyard is wrapped around the luff extrusion. • The furling line is not free to run or has become tangled. • The forestay is too slack. • Dirt and salt in the bearings. • Too much strain on the halyard. 	<ul style="list-style-type: none"> • Ease the halyard slightly and try to reverse the system. Refer to the Assembly and Operating manual, Chapter 5 & 10, "Halyard routing". • Furl the system. Free the halyard. • Slacken or free the furling line. • Tension the forestay, first of all by tensioning the backstay adjuster or backstays. If this doesn't help, decrease the length of the Furlex-system. Refer to the Operating manual, Chapter 14, "Adjusting the forestay length". • Rinse the bearings with fresh water and lubricate with Furlex grease. • Ease the halyard off.
18.2	"The sail will not furl, is hard to furl or can only be partly furled"	<ul style="list-style-type: none"> • The jib halyard is wrapped around the luff extrusion. • Another halyard is wrapped around the luff extrusion. • There is no line left on the drum. • The forestay is too slack. • Excessive wind pressure on the sail. • Windward sheet is not released. • The sheet has become tangled. • The free turn is not functioning. • Large turning angles in the furling line route which increase friction. • Dirt and salt in the bearings. 	<ul style="list-style-type: none"> • Ease the halyard slightly and try to reverse the system. Refer to the Assembly and Operating manual, Chapter 5 & 10, "Halyard routing". • Unfurl the system. Free the halyard • Unfurl the sail. Take it down and wind more line on the drum. Alternatively, loosen the sheet, gather the sail around the system with a rope, wind more line on the drum. • Increase forestay tension. • Let the leeward sheet off more. • Release the sheet. • Sort out the sheet. • Rinse the bearings with fresh water and lubricate with Furlex grease. (look even att 18.9) • Reroute the furling line, avoiding large turning angles. • Rinse the bearings with fresh water and lubricate with Furlex grease.

	Problem	Probable cause	Action
		<ul style="list-style-type: none"> • The furling line has become tangled on the drum. • The line guide fitting chafes against the drum. • The halyard swivel is upside down. • Too much strain on the halyard. 	<ul style="list-style-type: none"> • Unfurl the sail and take it down. Rewind the furling line. Unfurl with slight drag on the furling line in future and avoid having too much line on the drum. • Loosen the fastening screw below the drum and adjust the fitting. • Fit the halyard swivel correctly. • Ease the halyard off a little.
18.3	”The system ‘wobbles’ when furling and unfurling”	<ul style="list-style-type: none"> • The forestay is too loose. 	<ul style="list-style-type: none"> • Tension the forestay and/or backstay.
18.4	”The sail unfurls after reefing or furling”	<ul style="list-style-type: none"> • The sail is not furled tightly enough. • The furling line is not belayed. 	<ul style="list-style-type: none"> • Furl with some drag on the line. • Furl and belay the furling line.
18.5	”The sail is hard to hoist”	<ul style="list-style-type: none"> • The luff tape is too thick. • The sail is caught on something or is not sufficiently loose on the foredeck. • Fault in halyard routing. • Dirt and salt in the luff groove. 	<ul style="list-style-type: none"> • Return the sail to the sailmaker and refer to Furlex manual, chapter 7.1.1 ”Table of sail measurements”. • Arrange the sail better on the foredeck. • Check the sheaves, winch etc. • Clean the luff groove.
18.6	”The luff cannot be tensioned”	<ul style="list-style-type: none"> • The halyard swivel comes into contact with the top guard. • The angle between the forestay and the halyard is too great. 	<ul style="list-style-type: none"> • The luff of the sail is too long. Have the sail shortened by the sailmaker. • Shorten the sail or move the halyard lead up.
18.7	”The sail cannot be taken down”	<ul style="list-style-type: none"> • The halyard is wrapped around the top of the luff extrusion. • The halyard wraps around the luff extrusion as the sail is coming down. • The halyard is stuck. 	<ul style="list-style-type: none"> • Ease the halyard off and try to reverse the system. Refer to the Assembly and Operating Manual, Chapter 5&10 ”Halyard routing”. • Tension the halyard manually keeping a slight drag on it while taking the sail down. • Check the halyard routing (sheaves, stoppers etc)
18.8	”The sail’s UV protection is on the inside of the furled sail”	<ul style="list-style-type: none"> • The furling line is wound on the drum in the wrong direction. 	<ul style="list-style-type: none"> • Remove the sheet from the sail and gather the sail around the Furlex-system with a rope. Pull on the line until the drum is empty. Wind a couple of turns on the drum by hand in the right direction. Unfurl the sail. Furl again, checking the number of turns of furling line on the drum.
18.9	”The sail is wrinkled at the tack”	<ul style="list-style-type: none"> • The tack ring was twisted in the wrong direction before tacking the sail. • The sail is old or incorrectly cut. 	<ul style="list-style-type: none"> • Unfurl the sail and ease off the halyard. Undo the tack snap shackle. Rotate the tack ring ”around the system” and retack the sail. Furl slowly and check that the furling of the tack is retarded by one revolution in relation to the luff extrusion. • Consult your sailmaker.
18.10	”The leach flogs despite sheeting hard”	<ul style="list-style-type: none"> • Incorrect sheeting point. • Incorrectly tensioned leach line. • The sail is old or incorrectly cut. 	<ul style="list-style-type: none"> • Move the sheeting point forward. • Adjust the leach line (Consult your sailmaker). • Consult your sailmaker.
18.11	”The leach closes (bends inwards)”	<ul style="list-style-type: none"> • Incorrect sheeting point. • The sail is old or incorrectly cut. 	<ul style="list-style-type: none"> • Move the sheeting point backwards. • Consult your sailmaker.

19 Checklist

Go through the checklist below and make sure that all the important instructions have been carried out. This will ensure that the Furlex-system functions safely and reliably under all conditions.

19.1 Points to check before sailing	See Chapter
<input type="checkbox"/> Check that the angle between the halyard and forestay is 5–10° when the sail is hoisted.	5
<input type="checkbox"/> Check that the clearance between the halyard swivel and the top guard is not less than 50 mm.	7.1
<input type="checkbox"/> Do all the sails used have the maximum luff length or an extension pendant?	7.1
<input type="checkbox"/> Check that no halyard can get caught in the halyard swivel or wrapped around the luff extrusion.	5.3
<input type="checkbox"/> Check that the line guide eye does not deflect the furling line too much, as this can cause extra friction and wear.	6.3
<input type="checkbox"/> Check that the free turn is functioning, i.e. the tack swivel is turned in the right direction. Some load on the sheet should cause the luff section to rotate one revolution before the tack rotates.	12.1
<input type="checkbox"/> Check that the line guide fitting does not contact the line drum flanges.	4.3
<input type="checkbox"/> Check that the Furlex stay articulates freely at the upper and lower attachment.	3.1
<input type="checkbox"/> Check that all the split pins are secured.	3.3

We are sure that your Furlex will give you many years of enjoyment and wish you and your crew happy sailing.



www.seldenmast.com

Sweden: Seldén Mast AB, Tel +46 (0)31 69 69 00, e-mail info@seldenmast.com **UK:** Seldén Mast Ltd., Tel +44 (0)1329 50 40 00, e-mail info@seldenmast.co.uk **USA:** Seldén Mast Inc., Tel +1 843-760-6278, e-mail info@seldenus.com **Denmark:** Seldén Mast A/S, Tel +45 39 18 44 00, e-mail info@seldenmast.dk **the Netherlands:** Seldén Mid Europe B.V., Tel +31 (0)111-698 120, e-mail info@seldenmast.nl
France: Seldén Mast SAS, Tel 33 (0) 251 362 110, e-mail info@seldenmast.fr