

Spare Parts List

Seldén in-mast furling and reefing system

Type: **RA MK III**
RB MK III
RC MK III

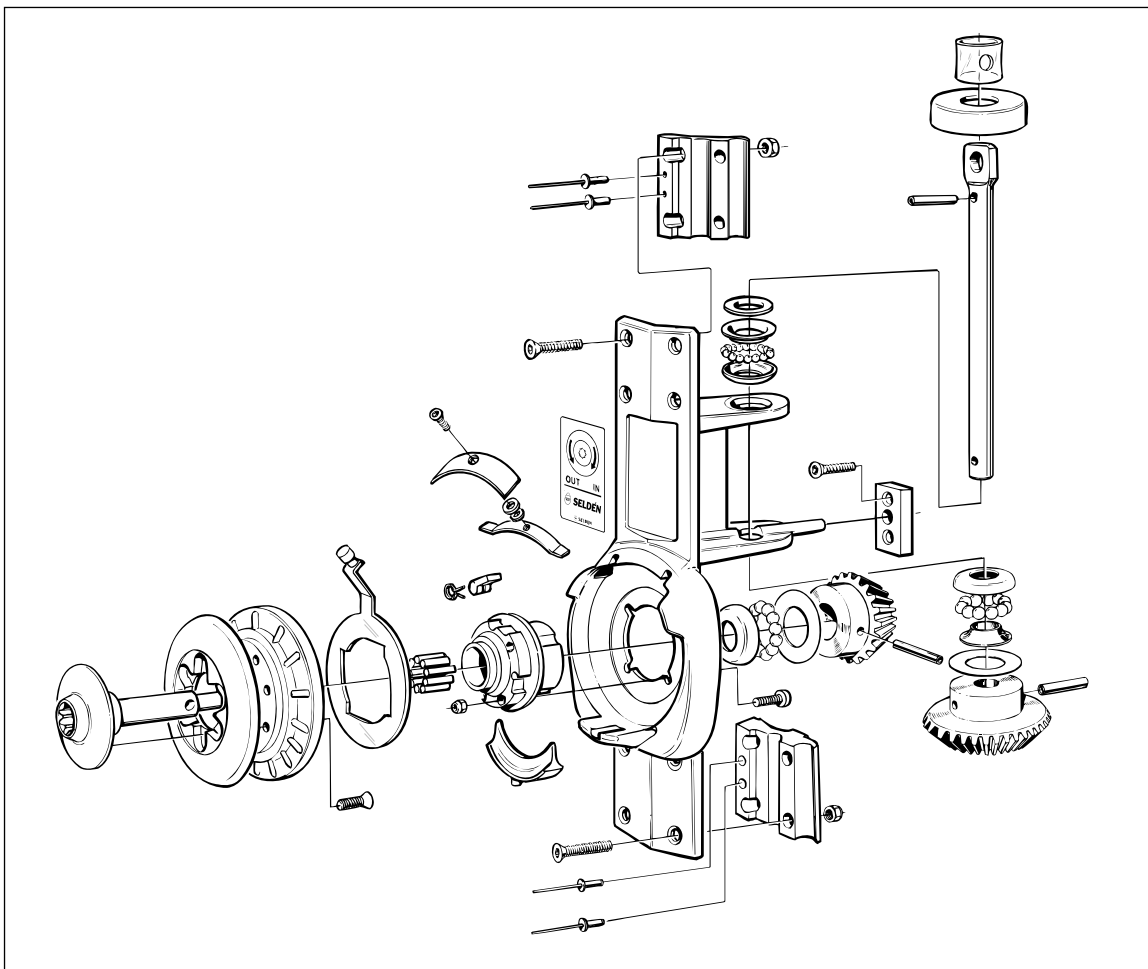

General information

Identification of in-mast furling mast model

As a result of continued product development, some parts have been replaced and improved over the years. To help identify which version (Mk No.) you have, the physical features are listed in the table below.

If you received this spare parts lists with a new mast, then you have the Mk III-version. Please disregard other models.

Spare parts lists can be obtained from Seldén.

In contacts with Seldén the production number, engraved in the section close to the heel, can also be used for identification.

	Parts	Mk I	Mk II	Mk III
RA	<ul style="list-style-type: none"> • Luff extrusion • Furling gear 	<ul style="list-style-type: none"> • Not tensioned • Front cover hides centre of black linedriver. Ratio 1:1 	<ul style="list-style-type: none"> • Tensioned. Adjustment screw locked by round Al. Al tube • Front cover hides centre of black linedriver. Ratio 1:1 	<ul style="list-style-type: none"> • Tensioned. Adjustment screw locked by round Al. Al tube • Black/silver linedriver fully exposed Ratio 1:1.75
RB	<ul style="list-style-type: none"> • Luff extrusion • Tack attachment • Sail entry • Furling gear • Bombacket 	<ul style="list-style-type: none"> • Luff groove Ø 10 2 flat surfaces Adjustment screw locked by square locking tube • Swinging tack attachment • Slotted tube • Silver linedriver. Ratio 1:1.5 • Boom bracket incorporated in furling gear. 	<ul style="list-style-type: none"> • Luff groove Ø 10 2 flat surfaces Adjustment screw locked by round Al. Al. tube. • Fixed tack hook. • Milled in luff extrusion • Silver linedriver. Ratio 1:1.5 • Boom bracket separate from furling gear. 	<ul style="list-style-type: none"> • Luff groove Ø 8. 1 flat surface Adjustment screw locked by round Al. Al. tube. • Fixed tack hook. • Open groove. No milling • Black/Silver linedriver. Ratio 1:2 • Boom bracket separate from furling gear.
RC	<ul style="list-style-type: none"> • Luff extrusion • Tack attachment • Sail entry • Furling gear • Bombacket 	<ul style="list-style-type: none"> • Adjustment screw locked by square locking tube (St.st) • Swinging tack attachment • Slotted tube • Silver linedriver. Ratio 1:1.5 • Boom bracket incorporated in furling gear. 	<ul style="list-style-type: none"> • Adjustment screw locked by round Al. Al. tube. • Fixed tack hook. • Milled in luff extrusion • Silver linedriver. Ratio 1:1.5 • Boom bracket separate from furling gear. 	<ul style="list-style-type: none"> • Adjustment screw locked by round Al. Al. tube. • Fixed tack hook. • Milled in luffextrusion • Black/Silver linedriver. Ratio 1:2 • Boom bracket separate from furling gear.

Note: Early masts of the smaller RA size were made by Kemp Masts Ltd, using different driving methods. These were called "Reefin". For spares & assistance, contact Seldén Masts Ltd in England.



If the halyard swivel or furling gear are dismantled, they can be difficult to re-assembly as the balls are loose in the bearing races. Use grease as temporary adhesive during assembly. For service assistance, contact your Seldén dealer.

You will find Seldén- & Furlex dealers list in the Furlex spare parts list or at Internet (see last page).

Seldén Mast AB reserves the right to alter the design or specification without prior warning; to allow unrestricted future product development.

Contents

	<i>Page</i>
<i>General information</i>	2
<i>Halyard swivel</i>	4
<i>Furling gear</i>	6
<i>Top swivel</i>	10
<i>Tack assembly</i>	12
<i>Sail feeder assembly</i>	16
<i>Luff extrusion</i>	16
<i>Swinging lead</i>	18
<i>Additional items</i>	20

Halyard swivel

Description A

Item	Description	Type RA Mk III Mast extrusion			Type RB Mk III Mast extrusion			Type RC Mk III Mast extrusion		
		Dimension	Qty	Part no	Dimension	Qty	Part no	Dimension	Qty	Part no
		Assembly number → 540-080-01			Assembly number → 539-158-01			Assembly number → 540-253-01		
A1	Hub	Ø 60x100	1	540-081	Ø 52x120	1	539-581	Ø 62x130	1	539-281
A2	Ball bearing ring - inner	Ø 57x7	2	539-309	-	-	-	-	-	-
A3	Sliding sleeve	-	-	-	Ø 64x140	1	540-159	Ø 80x150	1	539-254
A4	Ball	Ø 6	54	539-034	Ø 6	60	539-034	Ø 8	54	539-128
A5	Ball bearing ring - outer	Ø 62x11.5	2	539-310	Ø 68/52-16	2	539-272	Ø 83/64-16	2	539-270
A6	Eye ring	Ø 63x90	1	540-080	Ø 77x140	1	540-158	Ø 92x155	1	540-253
A7	Split pin	Ø 2.9x32	1	301-525	Ø 2.9x32	1	301-525	Ø 2.9x32	1	301-525
A8	Shackle	Ø 6x13x24	1	307-082	Ø 6x13x25	1	307-023	Ø 8x16x32	1	307-025
A9	Pin	Ø 8x50	1	166-232	Ø 10x37	1	166-222	Ø 12x42	1	166-223
A10	Sliding insert port	-	-	-	52x52	1	540-166	52x52	1	540-166
A11	Sliding insert STB	-	-	-	52x52	1	540-165	52x52	1	540-165
A12	Collar	Ø 57x8	1	540-082	-	-	-	-	-	-
A13	Selft. screw	RTS 4.2x19	1	171-040	3.5x9.5	1	171-047	3.5x9.5	1	171-047
A14	Washer	-	-	-	Ø 62/52-3	1	164-441	Ø 74/62-3	1	164-440
A15	Spirolox ring	-	-	-	-	1	301-508	-	1	301-507

Type RA MK III

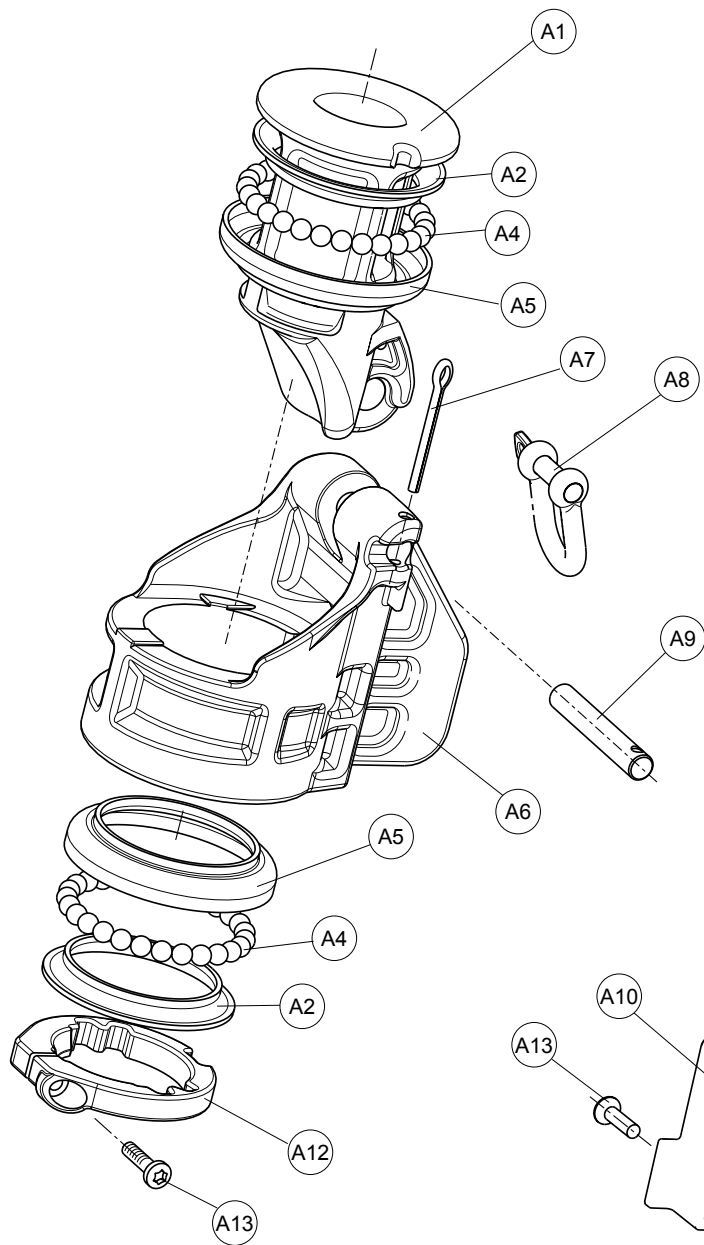

Type RB/RC MK III

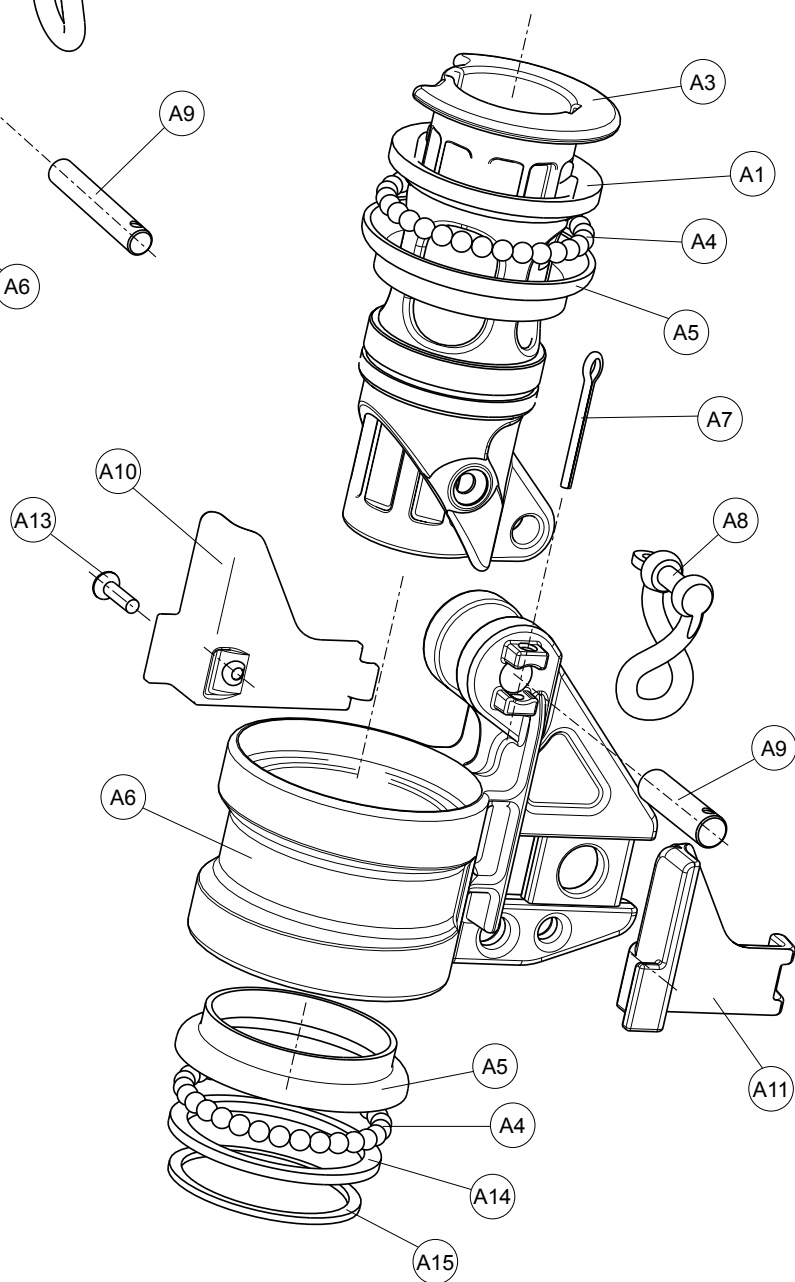

Furling gear

Description B

Item	Description	Type RA Mk III Mast extrusion			Type RB Mk III Mast extrusion			Type RC Mk III Mast extrusion											
		Dimension	Qty	Part no	Dimension	Qty	Part no	Dimension	Qty	Part no									
		R190/94 R213/104 R235/116			F176 F194 F212 F228			R232/126 R260/150			F212 F228 F246 F265 F286			R290/150			F265 F286 F305 F324		
		Assembly number → 540-047-01			Assembly number → 540-142-01			Assembly number → 540-142-01			Assembly number → 540-142-01								
B1	Furling gear bracket	210x110	1	540-047	424x132	1	540-142	424x132	1	540-142									
B2	Label - Furling direction	-	-	-	73x43	1	591-268	73x43	1	591-268									
B3	Line driver half - outer	Ø 100/36-14	1	540-048	Ø 120/36	1	540-153	Ø 120/36	1	540-153									
B4	Line driver half - inner	Ø 100/35-25	1	540-049	Ø 120/36	1	540-152	Ø 120/36	1	540-152									
B5	Pawl	Ø 8x16	4	540-007	Ø 8x16	4	540-007	Ø 8x16	4	540-007									
B6	Spring	Ø 7/0.5	4	540-008	Ø 7/0.5	4	540-008	Ø 7/0.5	4	540-008									
B7	Hub assembly	Ø 80/22-48	1	540-143-01	Ø 80/22-48	1	540-143-01	Ø 80/22-48	1	540-143-01									
B8	Needle roller	Ø 5x25	15	166-175	Ø 5x25	15	166-175	Ø 5x25	15	166-175									
B9	Locking nut	M6	4	158-005	M6	4	158-005	M6	4	158-005									
B10	Shaft	Ø 20/75-120	1	540-053	Ø 20/75-120	1	540-053	Ø 20/75-120	1	540-053									
B11	Screw	MFT 6x20	6	162-031	MFT 6x20	6	162-031	MFT 6x20	6	162-031									
B12	Bevel gear	Ø 59/20-33	1	320-010 ²⁾	Ø 84/20-40	1	320-011 ³⁾	Ø 84/20-40	1	320-011 ³⁾									
B13	Spring pin	Ø 6x40	1	166-528	Ø 8x45	2	166-503	Ø 8x45	2	166-503									
B14	Ball	Ø 6	13	539-034	Ø 6	13	539-034	Ø 6	13	539-034									
B15	Ball bearing ring - outer	Ø 36x7	1	539-060	Ø 36x7	1	539-060	Ø 36x7	1	539-060									
B16	Ratchet controller	Ø 100x3	1	540-054	Ø 100x3	1	540-054	Ø 100x3	1	540-054									
B17	Line stripper	58x20	1	540-034	58x20	1	540-034	58x20	1	540-034									
B18	Screw	MRT 6x20	4	155-621	MRT 6x20	4	155-621	MRT 6x20	4	155-621									
B19	Bevel gear	Ø 44/20-26	1	320-009 ⁴⁾	Ø 54/20-41.5	1	320-012 ⁵⁾	Ø 54/20-41.5	1	320-012 ⁵⁾									
B20	Shaft	Ø 20x140	1	540-011	Ø 20x220	1	166-143	Ø 20x220	1	166-143									
B21	Washer	Ø 36/20-3	1	164-421	Ø 36/20-3	1	164-421	Ø 36/20-3	1	164-421									
B22	Protection cover	Ø 57/18-20	1	540-126	Ø 57/18-20	1	540-126	Ø 57/18-20	1	540-126									
B23	Hose	Ø 24/19-26	1	540-027	-	-	-	-	-	-									
B24	Ball bearing ring - inner	-	-	-	Ø 38x8	2	540-106	Ø 38x8	2	540-106									
B25	Ball	Ø 6	26	539-034	Ø 8	24	539-128	Ø 8	24	539-128									
B26	Ball bearing ring - outer	Ø 36x7	2	539-060	Ø 44x8	2	539-223	Ø 44x8	2	539-223									
B27	Cover	63.5x39	1	540-055	74x21	1	540-155	74x21	1	540-155									
B28	Backing plate	64x12	1	540-056	77x10	1	540-156	77x10	1	540-156									
B29	Spring pin	Ø 6x40	2	166-528	Ø 6x32	1	166-509	Ø 6x32	1	166-509									
B30	Screw	MFT 5x12	1	162-048	MFT 5x12	1	164-048	MFT 5x12	1	164-048									
B31	Lock washer	-	-	-	M5	1	164-051	M5	1	164-051									

To be continued on page 8

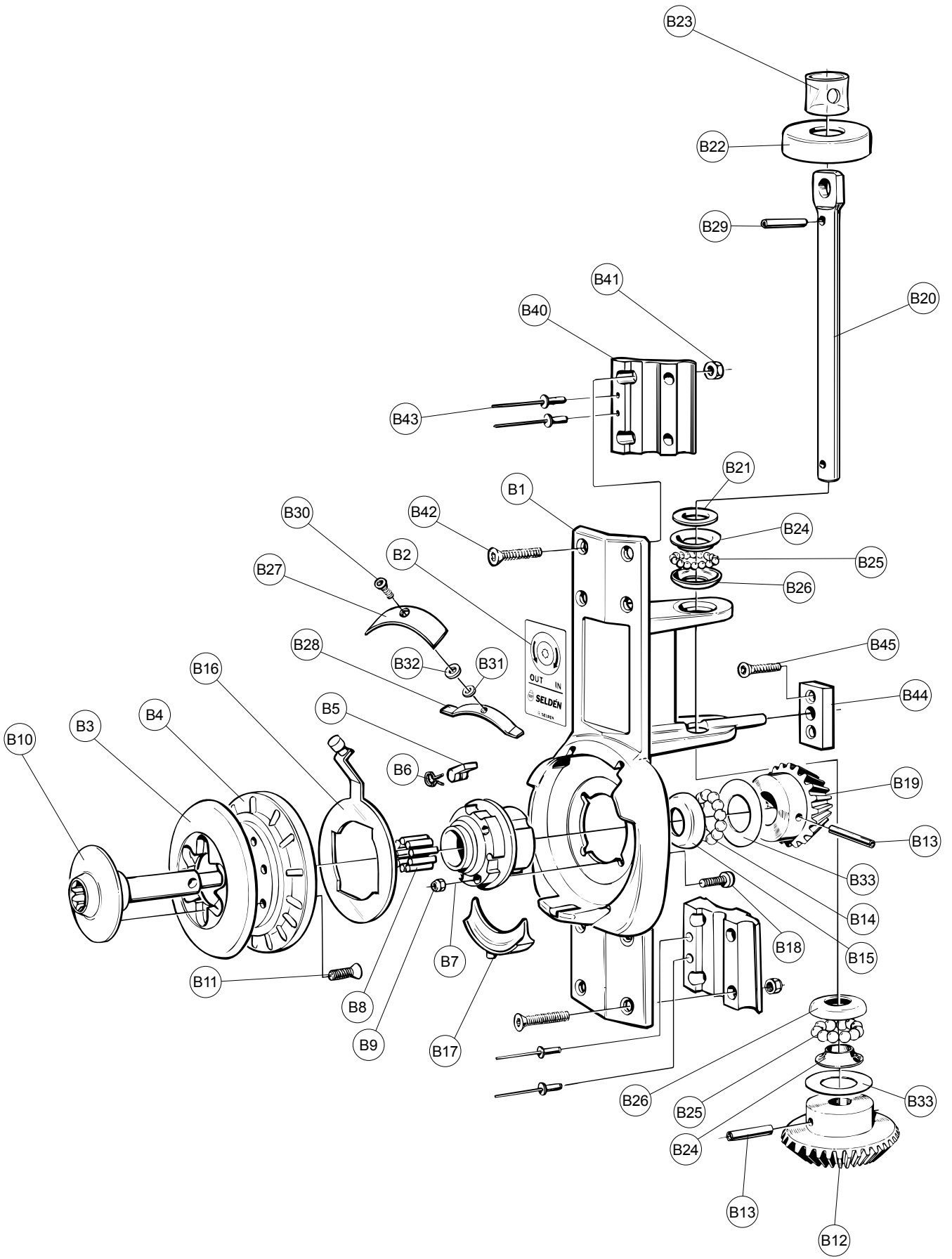

Furling gear (Continued from page 6.)

Description B

Item	Description	Type RA Mk III Mast extrusion			Type RB Mk III Mast extrusion			Type RC Mk III Mast extrusion		
		Dimension	Qty	Part no	Dimension	Qty	Part no	Dimension	Qty	Part no
		R190/94 R213/104 R235/116	F176 F194 F212 F228		R232/126 R260/150	F212 F228 F246 F265 F286		R290/150	F265 F286 F305 F324	
		Assembly number → 540-047-01			Assembly number → 540-142-01			Assembly number → 540-142-01		
B32	Washer	-	-	-	Ø 13/6-1.5	1	164-001	Ø 13/6-1.5	1	164-001
B33	Washer	-	-	-	Ø 37/21-0-5	3 ¹⁾	164-439	Ø 37/21-0-5	3 ¹⁾	164-439

B40	Backing plate	62x30	2	540-014	70x74	2	540-103	70x74	2	540-103
B41	Locking nut	M6	4	158-005	M8	8	158-006	M8	8	158-006
B42	Screw	MFT 6x40	4	162-024	MFT 8x40	8	162-037	MFT 8x40	8	162-037
B43	Pop rivet AD625	Ø 4.8x25.4	2	167-008	Ø 4.8x25.4	4	167-008	Ø 4.8x25.4	4	167-008
B44	Supporting bracket	-	-	-	-	-	-	70x30x15	1	540-125
B45	Screw	-	-	-	-	-	-	MFT 8x25	2	162-050

1)	Washers (164-439) are only intended as spacers to fill out possible excessive play. Correct quantities cannot therefore be specified. Washers may not be needed at all.									
2)	Only as an assembly B12-B13	1	320-010-01	-	-	-	-	-	-	-
3)	Only as an assembly B12-B13	-	-	-	1	320-011-01	-	1	320-011-02	-
4)	Only as an assembly B19 & B13	1	320-009-01	-	-	-	-	-	-	-
5)	Only as an assembly B19 & B13	-	-	-	1	320-012-01	-	1	320-012-01	-

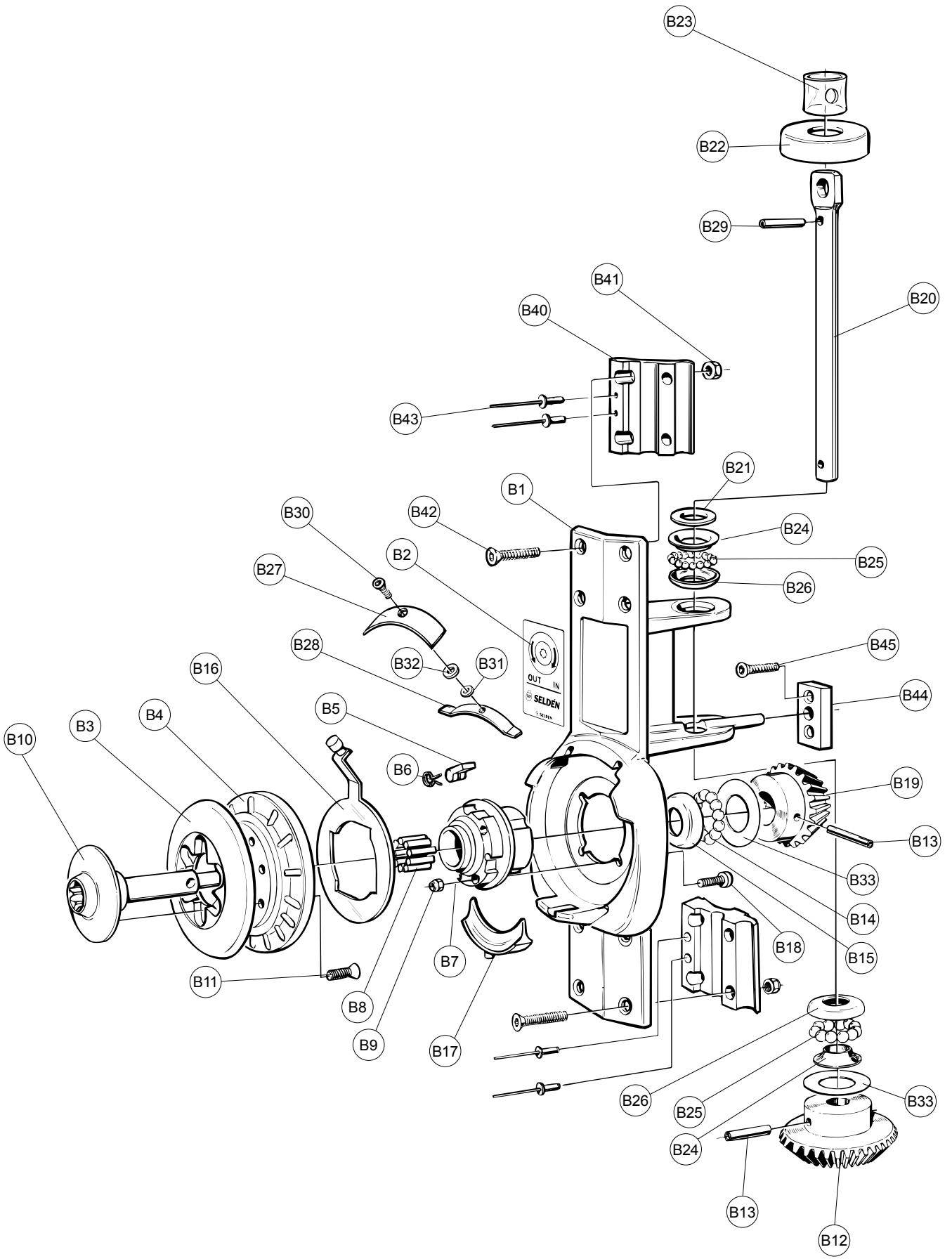

Top swivel

Description C

Item	Description	Type RA Mk 4 Mast extrusion			Type RB Mk 4 Mast extrusion			Type RC Mk III Mast extrusion		
		Dimension	Qty	Part no	Dimension	Qty	Part no	Dimension	Qty	Part no
		R190/94 R213/104 R235/116	F176 F194 F212 F228		R232/126 R260/150	F212 F228 F246 F265 F286		R290/150	F265 F286 F305 F324	
		Assembly number → 540-075-01			Assembly number → 540-164-01			Assembly number → 540-204-01		
C1	Ball bearing house half	Ø 23/20-370	2	540-075	Ø 55X91	2	540-164	Ø 66x105	2	540-204
C2	Screw	MRT 5x16	2	155-807	MRT 5x16	2	155-807	MRT 6x20	2	155-621
C3	Locking nut	M5	2	158-004	M5	2	158-004	M6	2	158-005
C4	Ball bearing ring - outer	Ø 44x8	1	539-223	Ø 44x8	1	539-223	Ø 52x8	1	539-111
C5	Balls	Ø 8	12	539-128	Ø 8	12	539-128	Ø 8	15	539-128
C6	Ball bearing eye	Ø 37x52.5	1	540-160	Ø 37x52.5	1	540-160	Ø 44/22-75	1	540-205
C7	Pop rivet LD639	Ø 4.8x9.9	4	167-007	-	-	-	-	-	-
C7	Pop rivet LD665	-	-	-	Ø 4.8x16.5	4	167-006	-	-	-
C7	Pop rivet LD870	-	-	-	-	-	-	Ø 6.4x17.8	6	167-002
C8	Screw	-	-	-	-	-	-	M6S 10x70	1	151-070
C9	Locking nut	-	-	-	-	-	-	M10	1	158-007
C10	Washer	-	-	-	-	-	-	Ø 16/8-1.5	2	164-401
C11	Bush	-	-	-	-	-	-	Ø 14/10-29.6	1	306-515
C12	Screw	-	-	-	-	-	-	M6S 8x90	1	151-049
C13	Locking nut	-	-	-	-	-	-	M8	1	158-006
C14	Strap	-	-	-	-	-	-	12x25x60	2	507-891

Type RA/RB MK 4

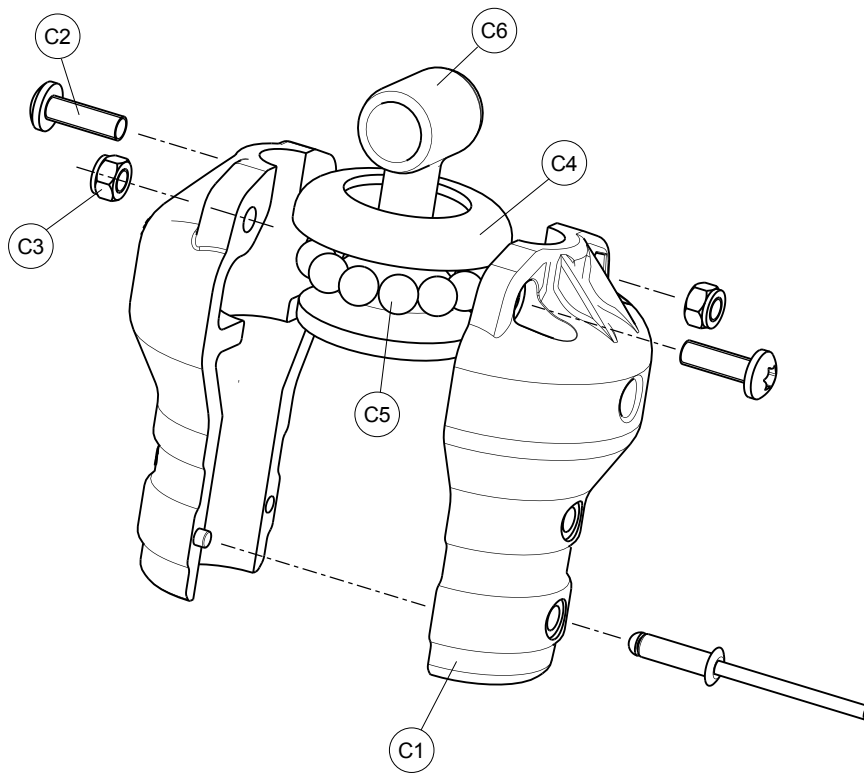

Type RC MK III

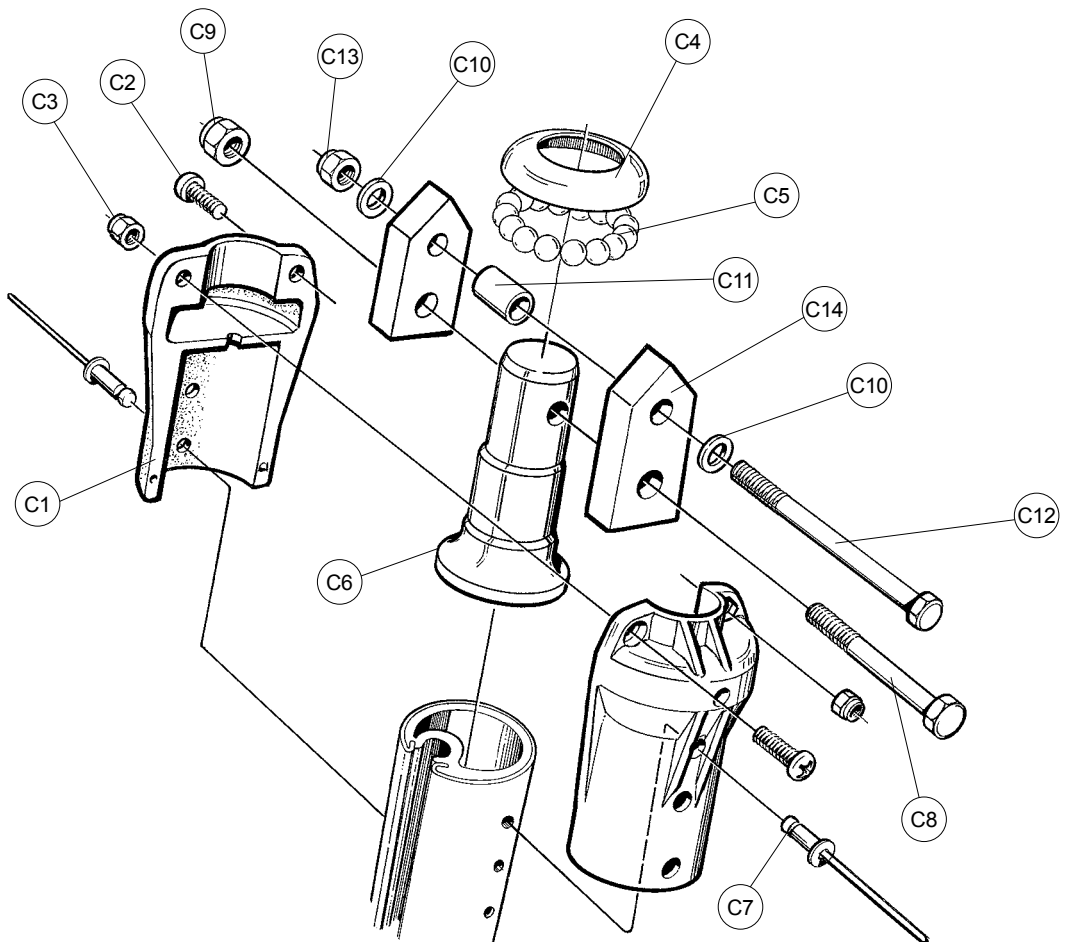

Tack assembly

Description D

		Type RA Mk III Mast extrusion 190/94 213/104 235/116		
Item	Description	Dimension	Qty	Part no
		Assembly number	→	540-710-11 540-710-12 ¹⁾
D1	Tack tube	Ø 24.5-291	1	540-710
D2	Insulator	Ø 26.5-40	1	540-071
D3	Tack hook	Ø 26.5/32-38	1	536-252
D4	Pop rivet LD639	Ø 4.8x9.9	2	167-007
D5	Wheel	Ø 70/26-20	1	319-599
D6	Split pin	Ø 3.7x33	1	301-045
D7	Reinforcement plug	Ø 20/15.6-50 Ø 20/15.6-240 ¹⁾	1	540-030 540-037 ¹⁾
D8	Pop rivet LD639	Ø 4.8x9.9	1	167-007
D9	Tensioning screw	M10/Ø 20-132	1	540-040
D10	Screw	MCS 6x16	1	155-015
D11	Pop rivet LD639	Ø 4.8x9.9	3	167-007
D12	Locking tube	Ø 29-250	1	540-067
D13	Label	40x20	1	591-191
	Sealing plug	Ø 4.8 rivet	1	319-510

D20	Adapter	Ø 30/26-65-65 Ø 30/26-65-45 ²⁾	1	540-065 540-012 ²⁾
D21	Clevis pin	Ø 6x36	1	165-007
D22	Split pin	Ø 2.3x12	1	301-047
D23	Clevis pin	Ø 6x36	1	165-007
D24	Split pin	Ø 2.3x12	1	301-047

1)	Type RA heavy duty version
2)	Type RA short version (Before 1996)

		Type RA Mk III Mast extrusion 232/126 260/150					
		Boom extrusion 143/76 171/94			Mast extrusion 200/117 250/140		
Item	Description	Dimension	Qty	Part no	Dimension	Qty	Part no
		Assembly number	→	540-136-01	Assembly number	→	540-137-01
D1	Tack tube	30/29-346	1	540-136	30/29-442	1	540-137
D2	Insulator	-	-	-	-	-	-
D3	Tack hook	Ø 38-42	1	536-251	Ø 38-42	1	536-251
D4	Pop Rivet LD 850	Ø 6.4x12.7	2	167-004	Ø 6.4x12.7	2	167-004
D5	Wheel	Ø 80/31.5-20	1	319-600	Ø 80/31.5-20	1	319-600
D6	Split pin	Ø 3.7x33	1	301-045	Ø 3.7x33	1	301-045
D7	Reinforcement plug	23/20-60	1	540-139	23/20-60	1	540-139

To be continued on page 14

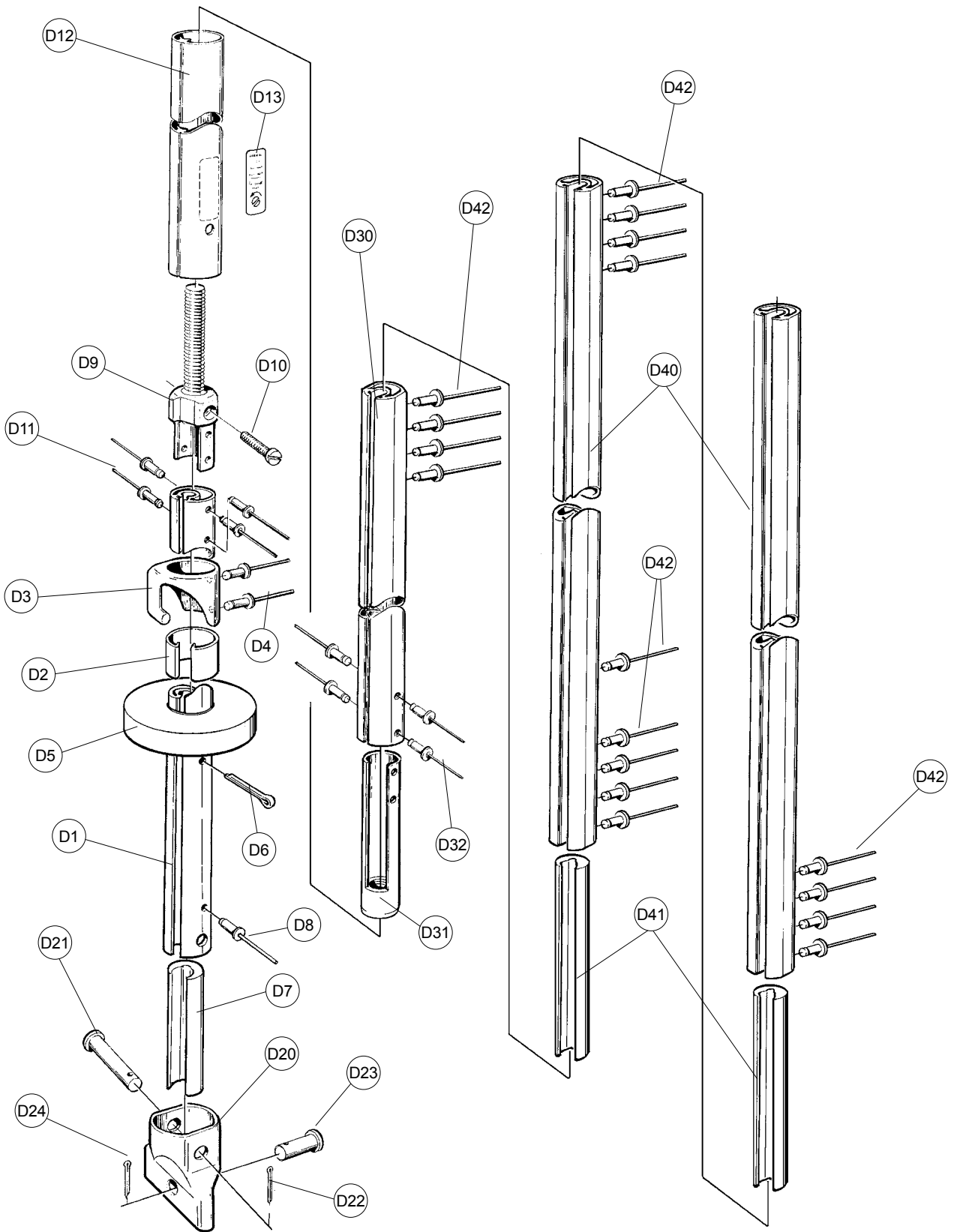

Tack assembly (Continued from page 12.)

Description D

Type RB Mk III Mast extrusion 232/126 260/150							
		Boom extrusion 143/76 171/94			Boom extrusion 200/117 250/140		
Item	Description	Dimension	Qty	Part no	Dimension	Qty	Part no
		Assembly number	→	540-136-01	Assembly number	→	540-137-01
D8	Pop rivet LD639	Ø 4.8x9.9	1	167-007	Ø 4.8x9.9	1	167-007
D9	Tensioning screw	M12/Ø 25-120	1	540-132	M12/25-120	1	540-132
D10	Screw	MCS 6x22	1	155-034	MCS 6x22	1	155-034
D11	Pop rivet LD639	Ø 4.8x9.9	4	167-007	Ø 4.8x9.9	4	167-007
D12	Locking tube	Ø 35x200	1	540-134	Ø 35x200	1	540-134
D13	Label	40x20	1	591-191	40x20	1	591-191
D20	Adapter	Ø 38x65	1	540-135	Ø 38x65	1	540-135
D21	Clevis pin	Ø 10x40	1	165-211	Ø 10x40	1	165-211
D22	Split pin	Ø 2.3x16	1	301-048	Ø 2.3x16	1	301-048
D23	Clevis pin	Ø 12x25	1	165-401	Ø 12x25	1	165-401
D24	Split pin	Ø 2.9x16	1	301-049	Ø 2.9x16	1	301-049
-	Sealing plug	Ø 4.8 rivet	1	319-510	Ø 4.8 rivet	1	319-510

Type RC Mk III Mast extrusion 290/150							
		Boom extrusion 143/76 171/94			Boom extrusion 200/117 250/140		
Item	Description	Dimension	Qty	Part no	Dimension	Qty	Part no
		Assembly number	→	540-229-01	Assembly number	→	540-230-01
D1	Tack tube	38/38-381	1	540-229	38/38-477	1	540-230
D2	Insulator	Ø 40x60	1	540-231	Ø 40x60	1	540-231
D3	Tack hook	Ø 45-95	1	540-224	Ø 45-95	1	540-224
D4	Pop rivet LD639	Ø 4.8x9.9	4	167-007	Ø 4.8x9.9	4	167-007
D5	heel	Ø 90/40-30	1	319-601	Ø 90/40-30	1	319-601
D6	Split pin	Ø 3.7x50	1	301-010	Ø 3.7x50	1	301-010
D7	Reinforcement plug	35/25-60	1	540-232	35/25-60	1	540-232
D8	Pop rivet LD639	Ø 4.8x9.9	1	167-007	Ø 4.8x9.9	1	167-007
D9	Tensioning screw	M16/Ø 32-177	1	540-225	M16/Ø 32-177	1	540-225
D10	Screw	MCS 6x22	1	155-034	MCS 6x22	1	155-034
D11	Pop rivet LD850	Ø 6.4x12.7	6	167-004	Ø 6.4x12.7	6	167-004
D12	Locking tube	Ø 44x300	1	540-227	Ø 44x300	1	540-227
D13	Label	40x20	1	591-191	40x20	1	591-191
D20	Adapter	Ø 44x78	1	540-228	Ø 44x78	1	540-228
D21	Clevis pin	Ø 12x53	1	165-403	Ø 12x53	1	165-403
D22	Split pin	Ø 2.9x16	1	301-049	Ø 2.9x16	1	301-049
D23	Clevis pin	Ø 12x25	1	165-401	Ø 12x25	1	165-401
D24	Split pin	Ø 2.9x16	1	301-049	Ø 2.9x16	1	301-049
-	Sealing plug	Ø 4.8 rivet	1	319-510	Ø 4.8 rivet	1	319-510

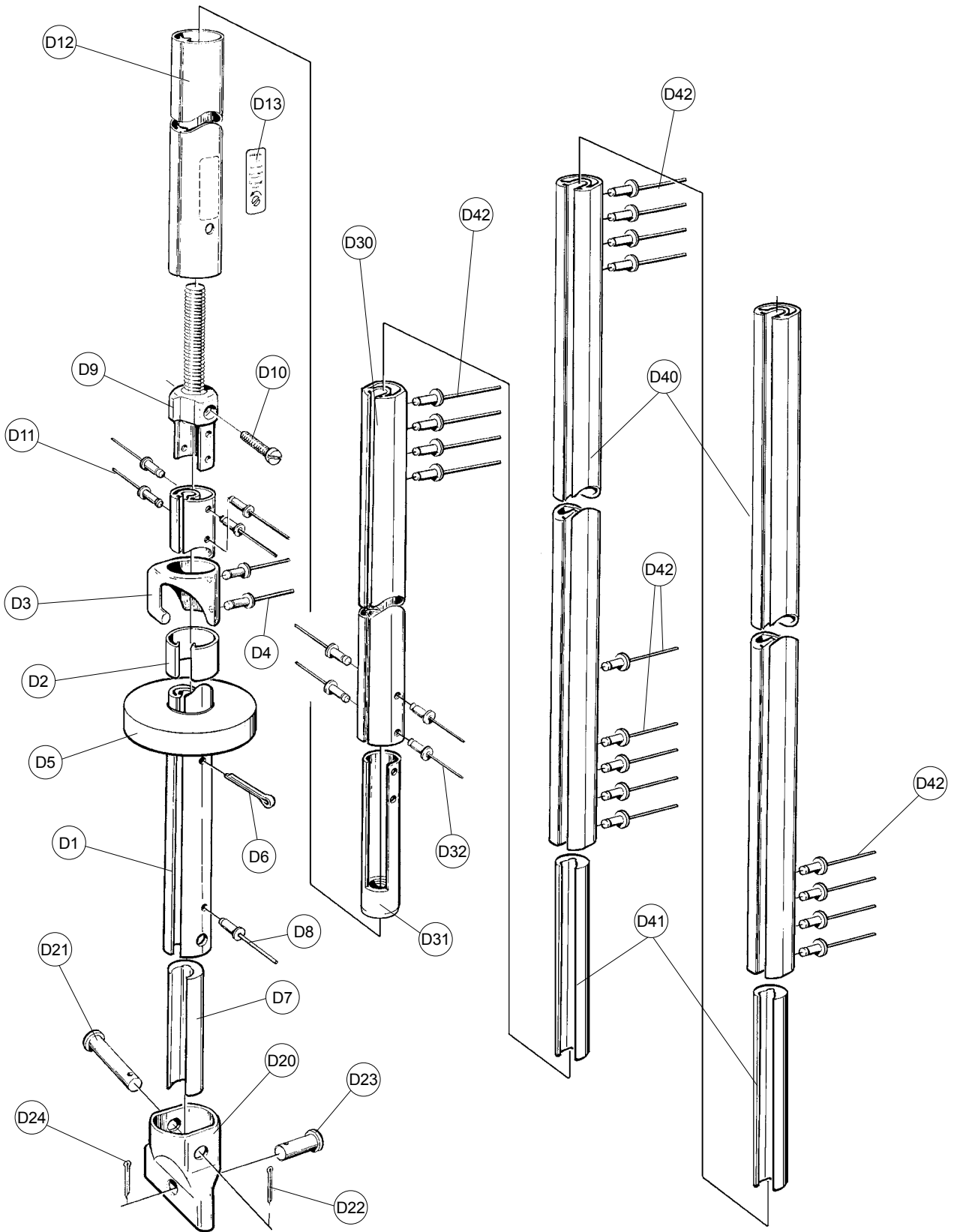

Sail feeder assembly

Description D

		Type RA Mk III Mast extrusion 190/94 213/104 235/116			Type RB Mk III Mast extrusion 232/126 260/150			Type RC Mk III Mast extrusion 290/150		
Item	Description	Dimension	Qty	Part no	Dimension	Qty	Part no	Dimension	Qty	Part no
		Assembly number → 540-711-11 540-711-12 1)			Assembly number → 540-154-01			Assembly number → 540-233-01		
D30	Sailfeeder extrusion	Ø 25.5-380 Ø 25.5-2000	1	540-711 540-073 1) 2)	Ø 30/29-390	1	540-154	Ø 38/38-330	1	540-233
D31	Tensioning screw body	M10/Ø 20-113	1	540-041	M12/Ø 25-101	1	540-133	M16/Ø 34-162	1	540-226
D32	Pop rivet LD639	Ø 4.8x9.9	3	167-007	Ø 4.8x9.9	4	167-007	-	-	-
D32	Pop rivet LD850	-	-	-	-	-	-	Ø 6.4x12.7	6	167-004
D41	Joint sleeve	-	-	-	-	-	-	33/25-200	1	540-215
D42	Pop rivet LD639	-	-	-	-	-	-	Ø 4.8x9.9	8	167-007
-	Sealing plug	-	-	-	-	-	-	Ø 4.8 rivet	8	319-510
-	Pop rivet LD639	Ø 4.8x9.9	1	167-007 1)	-	-	-	-	-	-
-	Reinforcement sleeve	Ø 20/15.6-1600	1	540-072 1)	-	-	-	-	-	-

1) Type RA heavy duty version

2) Luff extrusion cover (535-751) included

Luff extrusion

		Type RA Mk III Mast extrusion 190/94 213/104 235/116			Type RB Mk III Mast extrusion 232/126 260/150			Type RC Mk III Mast extrusion 290/150		
Item	Description	Dimension	Qty	Part no	Dimension	Qty	Part no	Dimension	Qty	Part no
		Assembly number → -			Assembly number → -			Assembly number → -		
D40	Luff extrusion assembly	Ø 24.5-6500	2	540-035-011)	Ø 30/29-7700	$\frac{2}{3}$ 2)	540-111-01	Ø 38/38-7700	3	540-217-01
D41	Joint sleeve	Ø 20/15-100	2	540-043	Ø 23/20-180	$\frac{1}{2}$ 2)	540-148	Ø 33/25-200	2	540-215
D42	Pop rivet LD639	Ø 4.8x9.9	9	167-007	Ø 4.8x9.9	$\frac{17}{25}$ 2)	167-007	Ø 4.8x9.9	41	167-007
-	Sealing plug	Ø 4.8 rivets	9	319-510	Ø 4.8 rivet	$\frac{17}{25}$ 2)	319-510	Ø 4.8 rivet	41	319-510

1) Luff extrusion cover included (RA: 540-036; RB: 540-112; RC: 540-218)

2) Boom extrusions 200/117 & 250/140

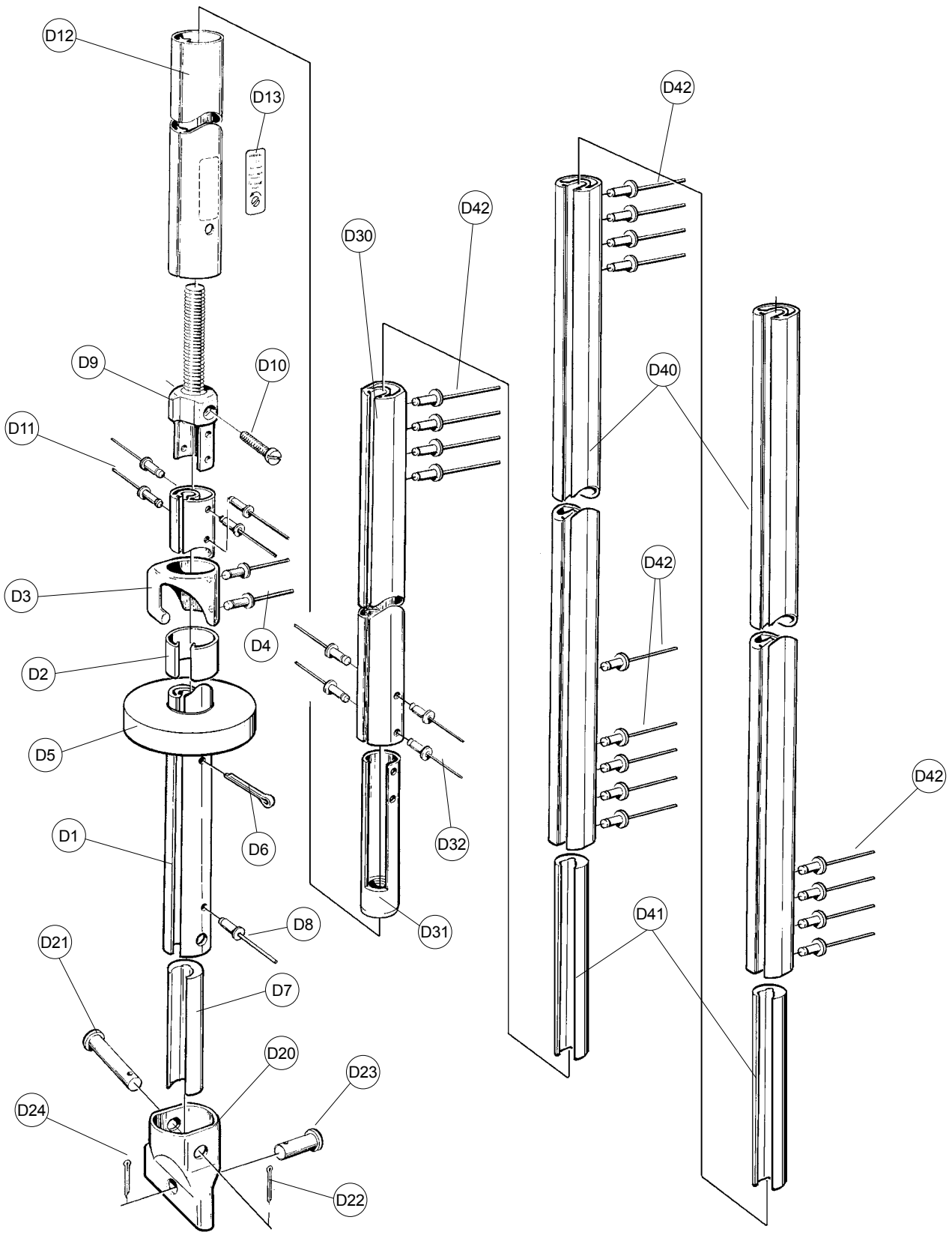

Swinging lead

Description E

		Type RA Mk III						Type RB Mk III		
		Mast extrusion 190/94 213/104			Mast extrusion 235/116			Mast extrusion ³⁾ 232/126 290/150		
Item	Description	Dimension	Qty	Part no	Dimension	Qty	Part no	Dimension	Qty	Part no
		Assembly number → 508-154-01			Assembly number → 508-160-01			Assembly number → 508-157-01		
E1	Sheave house bracket	150x94X63	1	508-154	150x120	1	508-160	150x120		508-157
E2	Swinging sheave house	2xØ 45x13	2	505-034	2xØ 70x16	2	505-039	2xØ 70x16		505-039
E3	Screw	M6S 8x30	2	151-043	M6S 8x30	2	151-043	M6S 8x30		151-043
E4	Washer-serrated	Ø 15/8.4-2.4	2	164-427	Ø 15/8.4-2.4	2	164-427	Ø 15/8.4-2.4		164-427
E5	Washer	Ø 16/8-1.5	2	164-401	Ø 16/8-1.5	2	164-401	-	-	-
E6	Locking nut	M8	2	158-006	M8	2	158-006	M8		158-006
E7	Sheave	Ø 45/8-13	4	504-320	Ø 70/12-16	4	504-332	Ø 70/12-16		504-332
E8	Clevis pin	Ø 8x50	2	165-108	Ø 12x53	2	165-403	Ø 12x53		165-403
E9	Split pin		-	-	Ø 2.9x18	2	301-050	Ø 2.9x18		301-050
-	Split ring ¹⁾	Ø 20x1.5	2	301-015	-	-	-	-	-	-
E11	Separator	-	-	-	72x59	2	537-034	72x59		537-034
-	Pop rivet LD 870 ²⁾	Ø 6.4x17.8	8	167-002	Ø 6.4x17.8 (long)	6	167-025	-	-	-
E13	Backing plate	-	-	-	-	-	-	70x74		540-103
E14	Locking nut	-	-	-	-	-	-	M8		158-006
E15	Screw	-	-	-	-	-	-	MFT 8x40		162-037
E16	Pop rivet LD665	-	-	-	-	-	-	Ø 4.8x16.5		167-006

1)	Split ring (not shown) replacing split pin (E9) in assembly 508-154-01
2)	Pop rivets (not shown) replacing fastening components (E13 - E16) in assemblies 508-154-01 & 508-160-01
3)	Swinging lead cannot be fitted to mast extrusion 290/150

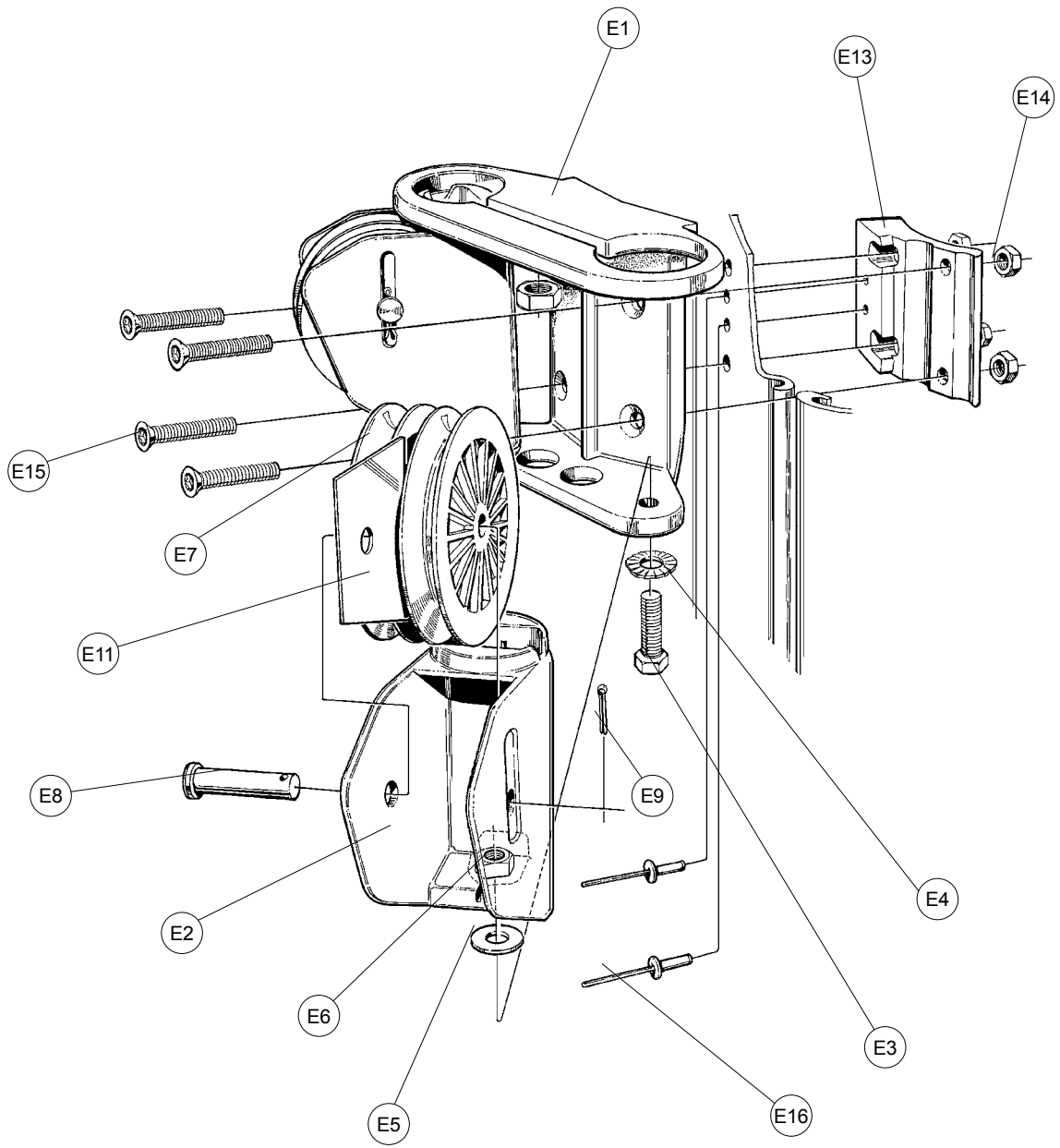

Additional items

Description F

Item	Description	Type RA Mk III Mast extrusion 190/94 213/104 235/116			Type RB Mk III Mast extrusion 232/126 260/150			Type RC Mk III Mast extrusion 290/150			
		Dimension	Qty	Part no	Dimension	Qty	Part no	Dimension	Qty	Part no	
		Assembly number →			-	Assembly number →			-	Assembly number →	
F1	Cover	57x126	2	540-026	72x207	2	540-120	72x207	2	540-120	
F2	Sail slot cover	-	-	-	38x20	1 ¹⁾	535-634	38x20	1 ¹⁾	535-634	
F3	Grease hole cover	Ø 44	2	319-609	Ø 44	2	319-609	Ø 44	2	319-609	
F4	Lubricating grease	100g	1	312-501	100g	2	312-501	100g	1	312-501	
F5	Manual (Swedish)	A4	1	595-059-S ²⁾	A4	1	595-063-S	A4	1	595-063-S	
F5	Manual (English)	A4	1	595-059-E ²⁾	A4	1	595-063-E	A4	1	595-063-E	
F5	Manual (German)	A4	1	595-059-T ²⁾	A4	1	595-063-T	A4	1	595-063-T	
F6	Manual addition (Swedish)	A4	1	595-087-S	-	-	-	-	-	-	
F6	Manual addition (English)	A4	1	595-087-E	-	-	-	-	-	-	
F6	Manual addition (German)	A4	1	595-087-T	-	-	-	-	-	-	
F7	Spare parts list	A4	1	595-110-E	A4	1	595-110-E	A4	1	595-110-E	
F8	Internal separator	-	-	-	T=30	1	530-905 ⁶⁾ 530-907 ⁶⁾	T=30	1		
F9	Rope clutch	6 - 12 mm	1	511-134	6 - 12 mm	1	511-134	6 - 12 mm	1	511-134	
F10	Deck organizer ⁵⁾	3 sheaves	1	538-809-01	3 sheaves	1	538-809-01	3 sheaves	1	538-809-01	
F10	Deck organizer ⁵⁾	4 sheaves	1	538-810-01	4 sheaves	1	538-810-01	4 sheaves	1	538-810-01	
F11	Endless line	2x5000	1	611-011-05	2x7000	1	611-011-06	2x9000	1	611-011-07	
F12	Outhaul lead block ^{3) 4)}	R345		538-992-01	R345	1	538-992-01	-	-	-	
F12	Outhaul lead block ^{3) 4)}	R545	11	538-993-01	R545	1	538-993-01	R545	1	538-993-01	
F12	Outhaul lead block ^{3) 4)}	-	-	-	-	-	-	R645	1	538-994-01	
F13	U-lead ⁴⁾	"small"	1	508-124-01	"small"	1	508-124-01	"small"	1	508-124-01	

1)	Variable length. Length to be specified when ordered.
2)	Manual must be accompanied by manual addition (595-087-S/E/T)
3)	Size of lead block depends on boom size; 120/62 & 143/76: R345; 171/94: R545; 200/117 & 250/140: R645
4)	U-lead can be used instead of lead block and vice versa.
5)	Removable sheaves for endless line.
6)	232/126: 530-905; 260/150: 530-907

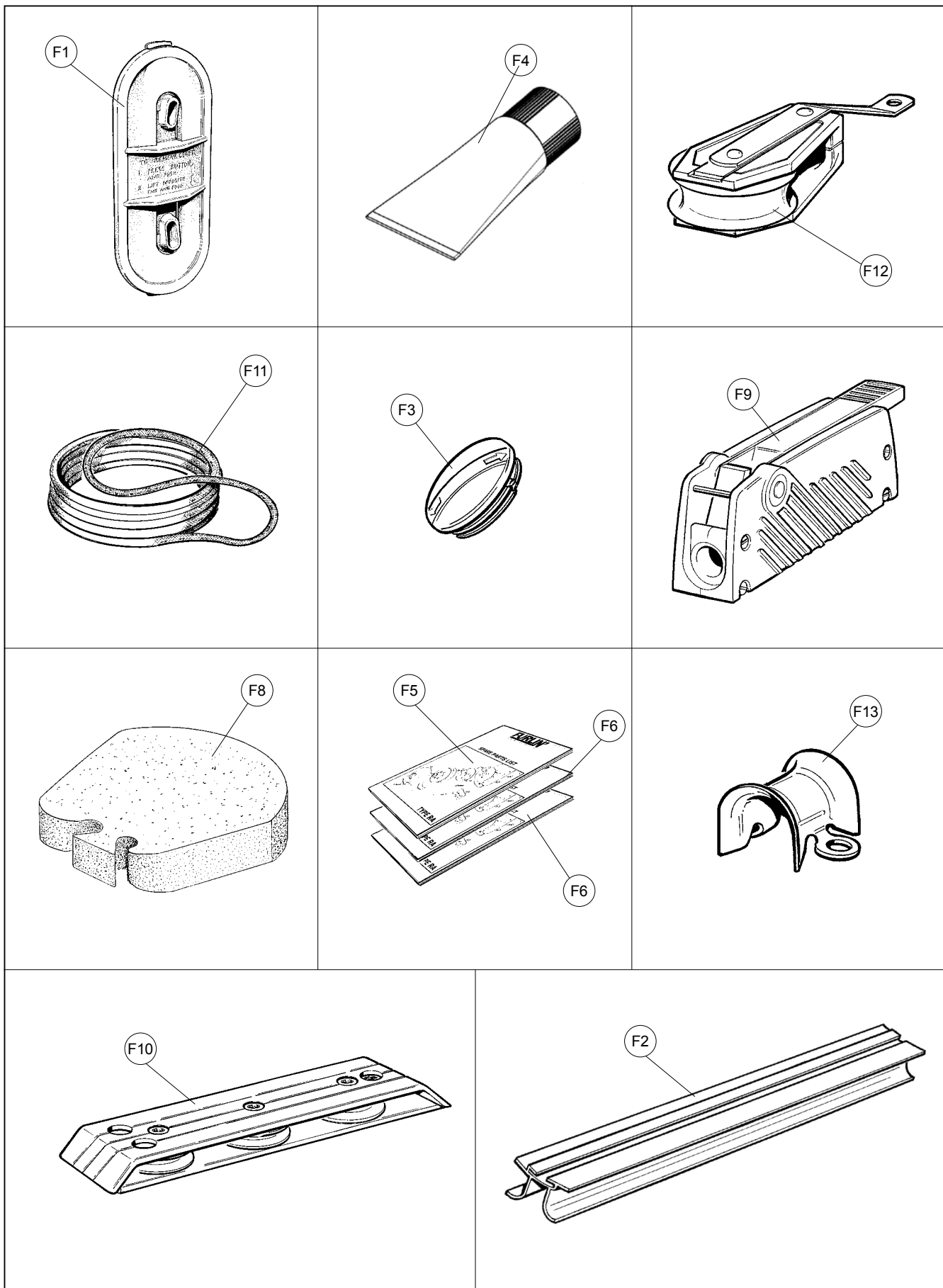

DINGHIES KEELBOATS YACHTS

Seldén Mast AB, Sweden
Tel +46 (0)31 69 69 00
Fax +46 (0)31 29 71 37
e-mail info@seldenmast.com

Seldén Mast Limited, UK
Tel +44 (0) 1329 504000
Fax +44 (0) 1329 504049
e-mail info@seldenmast.co.uk

Seldén Mast Inc., USA
Tel +1 843-760-6278
Fax +1 843-760-1220
e-mail info@seldenus.com

Seldén Mast A/S, DK
Tel +45 39 18 44 00
Fax +45 39 27 17 00
e-mail info@seldenmast.dk

Seldén Mid Europe B.V., NL
Tel +31 (0) 111-698 120
Fax +31 (0) 111-698 130
e-mail info@seldenmast.nl

Seldén Mast SAS, FR
Tel +33 (0) 251 362 110
Fax +33 (0) 251 362 185
e-mail info@seldenmast.fr

www.seldenmast.com

Dealer:

The Seldén Group is the world's leading manufacturer of masts and rigging systems in carbon and aluminium for dinghies, keelboats and yachts. The Group consists of Seldén Mast AB in Sweden, Seldén Mast A/S in Denmark, Seldén Mast Ltd in the UK, Seldén Mid Europe B.V. in the Netherlands, Seldén Mast SAS in France and Seldén Mast Inc in the USA. Our well known brands are Seldén and Furlex. The worldwide success of Furlex has enabled us to build a network of over 750 authorised dealers covering the world's marine markets. So wherever you sail, you can be sure of fast access to our service, spare parts and know-how.

